



GRAND-DUCHÉ DE LUXEMBOURG

Ministère du Développement durable
et des Infrastructures
Département des Transports

L-2938 Luxembourg

SOCIÉTÉ NATIONALE DE
CERTIFICATION ET D'HOMOLOGATION

s.à r.l.

Registre de Commerce: B 27180

L-5201 Sandweiler



Référence: e13*2016/1628*2017/656SRA1/P*0142*01

Annexes: - Rapport technique
- Fiche de renseignements du constructeur

Luxembourg, le 24 août 2018

CERTIFICAT DE RECEPTION UE PAR TYPE EU TYPE-APPROVAL CERTIFICATE

Communication concernant ⁽¹⁾: / Communication concerning the ⁽¹⁾:

- ~~la réception UE par type~~ / EU type-approval
- l'extension de la réception UE par type / extension of EU type-approval
- ~~le refus de la réception UE par type~~ / refusal of EU type-approval
- ~~le retrait de la réception UE par type~~ / withdrawal of EU type-approval

d'un type de moteurs / ~~d'une famille de moteurs~~ ⁽¹⁾, en ce qui concerne les émissions de gaz polluants et de particules polluantes conformément au règlement (UE) 2016/1628, modifié en dernier lieu par le règlement (délégué) ⁽¹⁾ .../... (de la Commission) ⁽¹⁾ (du Parlement européen et du Conseil) ⁽¹⁾
of an engine type / ~~engine family~~ ⁽¹⁾ with regard to gaseous and particulate pollutant emission pursuant to Regulation (EU) 2016/1628, as last amended by (Commission Delegated) ⁽¹⁾ Regulation .../... ⁽¹⁾ (of the European Parliament and of the Council) ⁽¹⁾

Numéro de réception UE par type ⁽³⁾:

EU type-approval number ⁽³⁾:

e13*2016/1628*2017/656SRA1/P*0142*01

Motif de l'extension/du refus/du retrait ⁽¹⁾:

Reason for extension/refusal/withdrawal ⁽¹⁾:

- Make changed
- Manufacturer changed

SECTION I SECTION I

1.1. **Marque(s) [dénomination(s) commerciale(s) du constructeur]:**

Make (trade name(s) of manufacturer):

POWERDYNE, WILKSUSA, GXNEWLAND

1.2. **Appellation(s) commerciale(s) (le cas échéant):**

Commercial name(s) (if applicable):

not applicable

1.3. **Nom et adresse du constructeur:**

Company name and address of manufacturer:

TAIZHOU NEWLAND MACHINERY CO., LTD.
NO.1390, West Gongren Road, Jiaojiang,
Taizhou City, P.R. China

1.4. **Nom et adresse du représentant agréé du constructeur (s'il y a lieu):**

Name and address of manufacturer's authorised representative (if any):

TAGMA D.O.O
SMARSKA CESTA 7C, 6000,
KOPER, SLOVENIA

- 1.5. Nom(s) et adresse(s) des usines d'assemblage/de fabrication:**
Name(s) and address(es) of assembly/manufacture plant(s): Taizhou Newland Machinery Co.,Ltd
NO.1390, West Gongren Road,
Jiaojiang, Taizhou City, Zhejiang Province,
P.R. China
- 1.6. Désignation du type de moteurs / désignation de la famille de moteurs / FT ⁽¹⁾:**
Engine type designation / engine family designation / FT ⁽¹⁾: **BS168F-1**
- 1.7. Catégorie et sous-catégorie du type de moteurs / de la famille de moteurs ⁽¹⁾⁽⁴⁾:**
Category and sub-category of the engine type / engine family ⁽¹⁾⁽⁴⁾: NRS-vr-1a
- 1.8. Catégorie de période de durabilité des caractéristiques d'émission:**
Emissions durability period category: ~~not applicable~~ / Cat 1 / ~~Cat 2~~ / ~~Cat 3~~ ⁽¹⁾
- 1.9. Phase d'émissions:**
Emissions stage: V / ~~SPE~~
- 1.10. Moteur destiné aux fraises à neige ⁽⁵⁾:**
Engine for snow throwers ⁽⁵⁾: ~~Yes~~ / No ⁽¹⁾

SECTION II
SECTION II

- 1. Autorité déléguée:**
Assigned authority: Société Nationale de Certification et d'Homologation
L-5201 Sandweiler
- Service technique responsable de la réalisation du ou des essais:**
Technical service responsible for carrying out the test(s): TÜV Rheinland Luxemburg GmbH
2a, Kalchesbruck
L-1852 Luxembourg
- 2. Date(s) du/des rapport(s) d'essai:**
Date(s) of the test report(s): 08.08.2018
- 3. Numéro(s) du/des rapport(s) d'essai:**
Number(s) of the test report(s): 87-2016/1628-1351/18-00

SECTION III
SECTION III

Le soussigné certifie, par la présente, l'exactitude de la description, faite par le constructeur dans la fiche de renseignements en annexe, du type de moteurs / ~~de la famille de moteurs~~⁽¹⁾ décrit(e) ci-dessus, dont un ou plusieurs échantillons représentatifs, choisis par l'autorité compétente en matière de réception, ont été présentés en tant que prototypes, ainsi que l'applicabilité au type de moteurs / ~~à la famille de moteurs~~⁽¹⁾ des résultats d'essai en annexe.
The undersigned hereby certifies the accuracy of the manufacturer's description in the attached information document of the engine type / ~~engine family~~⁽¹⁾ described above, for which one or more representative samples, selected by the approval authority, have been submitted as prototypes and that the attached test results apply to the engine type / ~~engine family~~⁽¹⁾.

- | | | |
|----|---|--|
| 1. | Le type de moteurs / la famille de moteurs⁽¹⁾ satisfait / ne satisfait pas⁽¹⁾ aux exigences définies dans le règlement (UE) 2016/1628.
The engine type / engine family ⁽¹⁾ meets / does not meet ⁽¹⁾ the requirements laid down in Regulation (EU) 2016/1628. | meets |
| 2. | La réception est accordée/étendue/refusée/retirée⁽¹⁾.
The approval is granted/extended/refused/withdrawn ⁽¹⁾ . | granted/extended/refused/withdrawn ⁽¹⁾ |
| 3. | La réception est accordée conformément à l'article 35 du règlement (UE) 2016/1628 et sa validité expire, dès lors, le jj/mm/aaaa⁽³⁾.
The approval is granted in accordance with Article 35 of Regulation (EU) 2016/1628 and the validity of the approval is thus limited to dd/mm/yyyy ⁽³⁾ . | not applicable |
| 4. | Restrictions de validité⁽³⁾⁽⁶⁾:
Restrictions to validity ⁽³⁾⁽⁶⁾ : | not applicable |
| 5. | Dérogations appliquées⁽³⁾⁽⁶⁾:
Exemptions applied ⁽³⁾⁽⁶⁾ : | not applicable |

Lieu:
Place:

Luxembourg

Date:
Date:

24 août 2018

Signature:
Signature:

**Pour le Ministre du Développement durable
et des Infrastructures**

Pour la SNCH



Marco FELTES
Inspecteur Principal 1^{er} en rang



Laurent LINDEN
Attaché de Direction



Pièces jointes:

Attachments:

- Dossier de réception.

Information package.

- Rapport(s) d'essai.

Test report(s).

- Le cas échéant, nom et spécimen de signature de la ou des personnes habilitées à signer les déclarations de conformité, ainsi qu'indication de leur fonction dans la société.

Where applicable, the name(s) and specimen(s) of the signature(s) of the person(s) authorised to sign statement of conformity and a statement of their position in the company.

- Le cas échéant, spécimen rempli de déclaration de conformité.

Where applicable, a completed specimen of a statement of conformity.

N.B.:

Si le présent modèle est utilisé pour la réception UE par type d'un moteur dans le cadre d'une dérogation pour de nouvelles technologies ou de nouveaux concepts, conformément à l'article 35, paragraphe 4, du règlement (UE) 2016/1628, l'intitulé du certificat est le suivant: «CERTIFICAT DE RÉCEPTION UE PAR TYPE PROVISoire, VALABLE UNIQUEMENT SUR LE TERRITOIRE DE LA/DU ...»⁽⁷⁾.

NB:

If this model is used for EU type-approval of an engine as an exemption for new technologies or new concepts, pursuant to Article 35(4) of Regulation (EU) 2016/1628, the heading of the certificate shall read "PROVISIONAL EU TYPE-APPROVAL CERTIFICATE VALID ONLY ON THE TERRITORY OF ..." ⁽⁷⁾.

ADDENDUM
ADDENDUM

PARTIE A — CARACTÉRISTIQUES DU TYPE DE MOTEURS / DE LA FAMILLE DE MOTEURS ⁽¹⁾
PART A — CHARACTERISTICS OF THE ENGINE TYPE / ENGINE FAMILY ⁽¹⁾

2.	Paramètres de conception communs du type de moteurs / de la famille de moteurs ⁽¹⁾ Common design parameters of the engine type / engine family ⁽¹⁾	
2.1.	Cycle de combustion: Combustion Cycle:	four stroke cycle / two stroke cycle / rotary/other ⁽¹⁾
2.2.	Modes d'allumage: Ignition Type:	Compression ignition / spark ignition ⁽¹⁾
2.3.1.	Disposition des cylindres dans le bloc: Position of the cylinders in the block:	∇ / in-line / radial / other (describe) ⁽¹⁾ : single
2.6.	Moyen principal de refroidissement: Main Cooling medium:	Air / Water / Oil ⁽¹⁾
2.7.	Mode d'aspiration de l'air: Method of air aspiration:	Naturally aspirated / pressure charged / pressure charged with charge cooler ⁽¹⁾
2.8.1.	Type(s) de carburant: Fuel Type(s):	Diesel (non road gas oil) / Ethanol for dedicated compression ignition engines (ED95) / Petrol (E10) / Ethanol (E85) / (Natural gas/Biomethane) / Liquid Petroleum Gas (LPG) ⁽¹⁾
2.8.1.1.	Sous-type de carburant (uniquement gaz naturel/biométhane): Sub Fuel type (Natural gas/Biomethane only):	Universal fuel — high calorific fuel (H gas) and low calorific fuel (L gas) / Restricted fuel high calorific fuel (H gas) / Restricted fuel low calorific fuel (L gas) / Fuel specific (LNG) ⁽¹⁾
2.8.2.	Alimentation en carburant: Fuelling arrangement:	Liquid-fuel only / Gaseous fuel only / Dual fuel type 1A / Dual fuel type 1B / Dual fuel type 2A / Dual fuel type 2B / Dual fuel type 3B ⁽¹⁾
2.8.3.	Liste des autres carburants pouvant être utilisés par le moteur déclarés par le constructeur conformément à l'annexe I, point 1, du règlement délégué (UE) 2017/654 (indiquer la référence à une norme ou à des spécifications reconnues): List of additional fuels compatible with use by the engine declared by the manufacturer in accordance with point 1 of Annex I to Delegated Regulation (EU) 2017/654 (provide reference to recognised standard or specification):	not applicable
2.8.4.	Lubrifiant ajouté au carburant: Lubricant added to fuel:	Yes / No ⁽¹⁾
2.8.5.	Système d'alimentation en carburant: Fuel supply type:	Pump (high pressure) line and injector / in-line pump or distributor pump / Unit injector / Common rail / Carburettor / port injector / direct injector / Mixing unit / other (specify) ⁽¹⁾
2.9.	Systèmes de gestion du moteur: Engine management systems:	Mechanical / electronic control strategy ⁽¹⁾

2.10.	Dispositifs divers: Miscellaneous devices:	Yes / No ⁽¹⁾
2.10.1.	Système de recyclage des gaz d'échappement (EGR): Exhaust gas recirculation (EGR):	Yes / No ⁽¹⁾
2.10.2.	Injection d'eau: Water injection:	Yes / No ⁽¹⁾
2.10.3.	Injection d'air: Air injection:	Yes / No ⁽¹⁾
2.10.4.	Autres (préciser): Others (specify):	not applicable
2.11.	Système de post-traitement des gaz d'échappement: Exhaust after-treatment system:	Yes / No ⁽¹⁾
2.11.1.	Catalyseur d'oxydation: Oxidation catalyst:	Yes / No ⁽¹⁾
2.11.2.	Système réducteur de NO_x avec réduction sélective des NO_x (adjonction d'un agent réducteur): DeNO _x system with selective reduction of NO _x (addition of reducing agent):	Yes / No ⁽¹⁾
2.11.3.	Autre système réducteur de NO_x: Other DeNO _x systems:	Yes / No ⁽¹⁾
2.11.4.	Catalyseur à trois voies combinant oxydation et réduction des émissions de NO_x: Three-way catalyst combining oxidation and NO _x reduction:	Yes / No ⁽¹⁾
2.11.5.	Système de post-traitement des particules avec régénération passive: Particulate after-treatment system with passive regeneration:	Yes / No ⁽¹⁾
2.11.6.	Système de post-traitement des particules avec régénération active: Particulate after-treatment system with active regeneration:	Yes / No ⁽¹⁾
2.11.7.	Autres systèmes de post-traitement des particules: Other particulate after-treatment systems:	Yes / No ⁽¹⁾
2.11.8.	Catalyseur à trois voies combinant oxydation et réduction des émissions de NO_x: Three-way catalyst combining oxidation and NO _x reduction:	Yes / No ⁽¹⁾
2.11.9.	Autres dispositifs de post-traitement (préciser): Other after-treatment devices (specify):	not applicable
2.11.10.	Autres dispositifs ou caractéristiques qui ont une forte incidence sur le niveau des émissions (préciser): Other devices or features that have a strong influence on emissions (specify):	not applicable

3. Caractéristiques principales du ou des types de moteurs

Essential characteristics of the engine type(s)

Item Number	Item Description	Parent Engine / Engine type	Engine types within the family (if applicable)
3.1.1.	Engine Type Designation:	BS168F-1	---
3.1.2.	Engine type designation shown on engine mark: Yes / No ⁽¹⁾	Yes	---
3.1.3.	Location of the manufacturer's statutory marking:	Enclosure	---
3.2.1.	Declared rated speed (rpm)	3600	---
3.2.1.2.	Declared rated net Power (kW):	4,20	---
3.2.2.	Maximum power speed (rpm):	3600	---
3.2.2.2.	Maximum net power (kW):	4,20	---
3.2.3.	Declared maximum torque speed (rpm):	3100	---
3.2.3.2.	Declared maximum torque (Nm):	11,2	---
3.6.3.	Number of Cylinders:	1	---
3.6.4.	Engine Displacement (cm ³):	196,0	---
3.8.5.	Device for recycling crank-case gases: Yes / No ⁽¹⁾	Yes	---
3.11.3.12.	Consumable reagent: Yes / No ⁽¹⁾	No	---
3.11.3.12.1.	Type and concentration of reagent needed for catalytic action:	not applicable	---
3.11.3.13.	NO _x sensor(s): Yes / No ⁽¹⁾	No	---
3.11.3.14.	Oxygen sensor: Yes / No ⁽¹⁾	No	---
3.11.4.7.	Fuel borne catalyst (FBC): Yes / No ⁽¹⁾	No	---

Particular conditions to be respected in the installation of the engine on non-road mobile machinery:

3.8.1.1.	Maximum allowable intake depression at 100 % engine speed and at 100 % load (kPa) with clean air cleaner:	1,9	---
3.8.3.2.	Maximum charge air cooler outlet temperature at 100 % speed and 100 % load (deg. C):	not applicable	---
3.8.3.3.	Maximum allowable pressure drop across charge cooler at 100 % engine speed and at 100 % load (kPa) (if applicable):	not applicable	---
3.9.3.	Maximum permissible exhaust gas backpressure at 100 % engine speed and at 100 % load (kPa):	5,0	---
3.9.3.1.	Location of measurement:	Exhaust port nearby	---
3.11.1.2.	Maximum temperature drop from exhaust system or turbine outlet to first exhaust after-treatment system (deg. C) if stated:	not applicable	---
3.11.1.2.1.	Test conditions for measurement:	not applicable	---

PARTIE B — RESULTATS DES ESSAIS
PART B — TEST RESULTS

- 3.8. Le constructeur a l'intention d'utiliser le signal UCE du couple pour la surveillance en service:**
Manufacturer intends to use ECU torque signal for in-service monitoring: Yes / No ⁽¹⁾
- 3.8.1. Couple mesuré au dynamomètre supérieur ou égal à 0,93 × couple UCE:**
Dynamometer torque greater than or equal to 0,93 × ECU torque: Yes / No ⁽¹⁾
- 3.8.2. Facteur de correction du couple UCE si le couple mesuré au dynamomètre est inférieur à 0,93 × couple UCE:**
ECU torque correction factor in case that dynamometer torque less than 0,93 × ECU torque: not applicable
- 11.1. Résultats relatifs aux émissions sur le cycle**
Cycle emissions results

Emissions	CO (g/kWh)	HC (g/kWh)	NO _x (g/kWh)	HC+NO _x (g/kWh)	PM (g/kWh)	PN #/kWh	Test Cycle ⁽⁸⁾
NRSC final result with DF	439,95	---	---	8,07	---	---	G2
NRTC Final test result with DF	---	---	---	---	---	---	---

- 11.2. Résultat concernant le CO₂:**
CO₂ result: 874,02 g/kWh

- (1) Biffer les options non utilisées ou n'indiquer que la ou les options retenues.**
Strike out the unused options, or only show the used option(s).
- (2) Indiquer uniquement la dernière modification dans le cas d'une modification portant sur un ou plusieurs articles du règlement (UE) 2016/1628, en fonction de la modification appliquée pour la réception UE par type.**
Indicate only the latest amendment in case of an amendment of one or more Articles of Regulation (EU) 2016/1628, according to the amendment applied for the EU type-approval.
- (3) Supprimer cette indication si elle n'a pas lieu d'être.**
Delete this entry when not applicable.
- (4) Indiquer l'option appropriée pour la catégorie et la sous-catégorie conformément au point 1.7 de la fiche de renseignements figurant dans la partie A de l'appendice 3 de l'annexe I.**
Indicate the applicable option for the category and sub-category in accordance with entry 1.7 of the information document set out in Part A of Appendix 3 to Annex I.
- (5) Indiquer si la réception s'applique à une famille de moteurs de catégorie NRS (<19 kW) constituée exclusivement de types de moteurs destinés aux fraises à neige.**
Indicate whether the approval is for NRS (<19 kW) engine family consisting exclusively of engine type for snow throwers.
- (6) Applicable uniquement pour la réception UE par type d'un type de moteurs ou d'une famille de moteurs bénéficiant d'une dérogation pour de nouvelles technologies ou de nouveaux concepts, conformément à l'article 35 du règlement (UE) 2016/1628.**
Applicable only for EU type-approval of an engine type or an engine family as an exemption for new technologies or new concepts, pursuant to Article 35 of Regulation 2016/1628.
- (7) Indiquer l'Etat membre.**
Indicate the Member State.
- (8) Indiquer le cycle d'essai conformément à la cinquième colonne des tableaux figurant à l'annexe IV du règlement (UE) 2016/1628.**
Indicate the test cycle in accordance with the fifth column of the Tables set out in Annex IV to Regulation (EU) 2016/1628.



GRAND-DUCHÉ DE LUXEMBOURG

Ministère du Développement durable
et des Infrastructures
Département des Transports

L-2938 Luxembourg

SOCIÉTÉ NATIONALE DE
CERTIFICATION ET D'HOMOLOGATION

s.à r.l.

Registre de Commerce: B 27180

L-5201 Sandweiler



Référence: e13*2016/1628*2017/656SRA1/P*0142*01

Annexes: - Rapport technique
- Fiche de renseignements du constructeur

Luxembourg, le 24 août 2018

INDEX DU DOSSIER DE RECEPTION INDEX TO TYPE-APPROVAL REPORT

	Numéro de réception: Approval number:	e13*2016/1628*2017/656SRA1/P*0142*01
	Révision: Revision:	00
	Marque de fabrique: Trade name or mark:	<u>POWERDYNE, WILKSUSA, GXNEWLAND</u>
	Type des moteurs: Engine type:	BS168F-1
1.	Procès-verbal d'essai: Test report:	N° 87-2016/1628-1351/18-00
	- Test report:	Page(s) 1 to 10;
	- List of modifications:	Appendix 0 - Page(s) 11.
2.	Dossier du constructeur: Report of the manufacturer:	N° <u>2016/1628-BS168F-1-01</u>
	- Manufacturer's information document:	Page(s) <u>1</u> to <u>19</u> ;
	- Attachments to the information document:	see: Index of attachments, page(s) <u>1</u> .
3.	Autres documents annexés: Other documents annexed:	not applicable
4.	Date de délivrance de la réception initiale: Date of issue of initial type approval:	09.07.2018
5.	Date de la dernière délivrance de pages révisées: Date of last issue of revised pages:	not applicable
6.	Date de la dernière délivrance d'une réception révisée: Date of last extension:	24.08.2018

Manufacturer : TAIZHOU NEWLAND MACHINERY CO., LTD.
Engine type designation : BS168F-1

TEST REPORT

according to Regulation of the European Parliament and of the Council

**on requirements relating to gaseous and particulate pollutant emission limits and type-approval
for internal combustion engines for non-road mobile machinery**

(EU) 2016/1628

including all amendments until

(EU) 2017/656

Approval status	
EU type – approval	: <u>e13*2016/1628*2017/656SRA1/P*0142*00</u>

Structure of report:

1. General Information
2. General engine information (test engine)
3. Documentation and information Check list (primary test only)
4. Reference fuel(s) used for test (complete relevant subparagraph(s))
5. Lubricant
6. Engine Speed
7. Engine Power
8. Conditions at test
9. Information concerning the conduct of the NRSC test:
10. Information concerning the conduct of the NRTC test (if applicable):
11. Final emissions results
12. Remarks concerning tested object(s)
13. Appendices
14. Statement of conformity

Manufacturer : **TAIZHOU NEWLAND MACHINERY CO., LTD.**
Engine type designation : **BS168F-1**

1. General information

- 1.1 Make (trade name of the manufacturer) : POWERDYNE, WILKSUSA, GXNEWLAND
- 1.2 Commercial name(s) (if applicable) : ---
- 1.3 Company name and address of manufacturer : TAIZHOU NEWLAND MACHINERY CO., LTD.
NO.1390, West Gongren Road, Jiaojiang, Taizhou
City, P.R. China
- 1.4 Name of technical service : TÜV Rheinland Luxemburg GmbH
- 1.5 Address of technical service : 2a, Kalchesbruck
L-1852 Luxembourg
- 1.6. Location of test : Nanjing Depurate Catalyst Co., Ltd.
No.18 Youshan Road , Gaochun Economic Develop
Zone , Nanjing 211300 , China
- 1.7 Date of test : November 11, 2017
- 1.8. Test report number : 87-2016/1628-1351/18-00
- 1.9. Information document reference number (if available) : 2016/1628-BS168F-1-01
- 1.10 Test report type: : Primary test/~~additional test~~/~~supplementary test~~
- 1.10.1. Description of the purpose of the test : Type approval test

2. General engine information (test engine)

- 2.1. Engine type designation/~~engine family designation~~/FF : BS168F-1
- 2.2. Engine identification number : 17A150002
- 2.3. Engine Category and subcategory : NRS-vr-1a
- 2.4. Condition of object(s) : ~~new, used, pretested~~
- 2.5. Worst case selection : The determination of “worst case scenario” was done according to internal procedures of the Technical Service (QMA 1.301.005, section 6.2.2.2.).
- 2.6. Remark : ---

3. Documentation and information Check list (primary test only)

- 3.1. Engine mapping documentation reference : See information document No.2016/1628-BS168F-1-01
- 3.2 Deterioration factor determination documentation reference : See information document No.2016/1628-BS168F-1-01
- 3.3. Infrequent regeneration factors determination documentation reference, where applicable : ---
- 3.4. NOx control diagnostic demonstration documentation : ---

Manufacturer : TAIZHOU NEWLAND MACHINERY CO., LTD.
Engine type designation : BS168F-1

reference, where applicable

- | | | | |
|--------|---|---|---|
| 3.5. | Particulate control diagnostic demonstration documentation reference, where applicable | : | --- |
| 3.6. | For engine types and engine families that use an ECU as part of the emission control system anti-tampering declaration documentation reference | : | --- |
| 3.7. | For engine types and engine families that use mechanical devices as part of the emission control system anti- tampering and adjustable parameters declaration and demonstration documentation reference | : | See information document No.2016/1628-BS168F-1-01 |
| 3.8. | Manufacturer intends to use ECU torque signal for in-service monitoring | : | Yes /No |
| 3.8.1. | dynamometer torque greater than or equal to $0,93 \times$ ECU torque | : | Yes /No |
| 3.8.2. | ECU torque correction factor in case that dynamometer torque less than $0,93 \times$ ECU torque | : | --- |
| 4. | Reference fuel(s) used for test (complete relevant subparagraph(s)) | | |
| 4.1. | <i>Liquid fuel for spark-ignition engines</i> | | |
| 4.1.1. | Make | : | SBF |
| 4.1.2. | Type | : | E10 |
| 4.1.3. | Octane number RON | : | 96.1 |
| 4.1.4. | Octane number MON | : | 85.9 |
| 4.1.5. | Ethanol content (%) | : | 9.6 |
| 4.1.6. | Density at 15 Deg.C (kg/m ³) | : | 0.753 |
| 4.2. | <i>Liquid fuel for compression-ignition engines</i> | : | --- |
| 4.2.1. | Make | : | --- |
| 4.2.2. | Type | : | --- |
| 4.2.3. | Cetane number | : | --- |
| 4.2.4. | Fame content (%) | : | --- |
| 4.2.5. | Density at 15 Deg.C (kg/m3) | : | --- |
| 4.3. | <i>Gaseous fuel — LPG</i> | : | --- |
| 4.3.1. | Make | : | --- |
| 4.3.2. | Type | : | --- |

Manufacturer : TAIZHOU NEWLAND MACHINERY CO., LTD.
Engine type designation : BS168F-1

4.3.3.	Reference fuel type	:	Fuel A/Fuel B
4.3.4.	Octane number MON	:	---
4.4.	<i>Gaseous fuel- Methane/biomethane</i>	:	---
4.4.1.	Reference fuel type	:	GR/G23/G25/G20
4.4.2.	Source of reference gas	:	specific reference fuel/pipeline gas with admixture
4.4.3.	For specific reference fuel	:	
4.4.3.1.	Make	:	---
4.4.3.2.	Type	:	---
4.4.4.	For pipeline gas with admixture	:	---
4.4.4.1.	Admixture(s)	:	Carbon dioxide/Ethane/Methane/Nitrogen/Propane
4.4.4.2.	The value of Sλ for the resulting fuel blend	:	---
4.4.4.3.	The Methane Number (MN) of the resulting fuel blend	:	---
4.5.	<i>Dual fuel engine (in addition to relevant sections above)</i>	:	---
4.5.1.	Gas energy ratio on test cycle	:	---
5.	Lubricant		
5.1.	Make(s)	:	MOBIL
5.2.	Type(s)	:	4T SF, SAE 20W-40
5.3.	SAE viscosity	:	107 cSt (90 mm ² /sec) at 40 °C 14.7 cSt (13.7mm ² /sec) at 100 °C
5.4.	Lubricant and fuel are mixed	:	Yes /No
5.4.1.	Percentage of oil in mixture	:	---
6.	Engine Speed		
6.1.	100 % speed (rpm):	:	3600
6.1.1.	100 % speed determined by	:	Declared rated speed/Declared maximum test speed (MTS)/Measured MTS
6.1.2.	Adjusted MTS if applicable (rpm)	:	---
6.2.	Intermediate speed	:	---
6.2.1.	Intermediate speed determined by	:	Declared intermediate speed/Measured intermediate speed/60 % of 100 % speed/75 % of 100 % speed/85 % of 100 % speed
6.3.	Idle speed	:	1650±200

Manufacturer : TAIZHOU NEWLAND MACHINERY CO., LTD.
Engine type designation : BS168F-1

7. Engine Power

7.1. Engine driven equipment (if applicable)

7.1.1. Power absorbed at indicated engine speeds by necessary auxiliaries for engine operation that cannot be fitted for the test (as specified by the manufacturer) to be stated in Table 1:

Table 1 Power absorbed by engine auxiliaries

Auxiliary type and identifying details	Power absorbed at indicated speed (kW) (complete relevant columns)						
	Idle	63%	80%	91%	Inter-mediate	Max. power	100%
---	---	---	---	---	---	---	---
---	---	---	---	---	---	---	---
---	---	---	---	---	---	---	---
Total ($P_{f,i}$) (kW):	---	---	---	---	---	---	---

7.1.2. Power absorbed at indicated engine speeds by auxiliaries linked with the operation of the non-road mobile machinery that cannot be removed for the test (as specified by the manufacturer) to be stated in Table 2:

Table 2 Power absorbed by non-road mobile machinery auxiliaries

Auxiliary type and identifying details	Power absorbed at indicated speed (kW) (complete relevant columns)						
	Idle	63%	80%	91%	Inter-mediate	Max. power	100%
---	---	---	---	---	---	---	---
---	---	---	---	---	---	---	---
---	---	---	---	---	---	---	---
Total ($P_{r,i}$) (kW):	---	---	---	---	---	---	---

7.2. Engine net power to be stated in Table 3:

Table 3 Engine net power

Condition	Power setting at indicated engine speed (kW) (complete relevant columns)		
	Intermediate	Max. power	100%
Maximum power measured at specified test speed ($P_{m,i}$) (kW)	---	---	4.20
Total auxiliary power from table 1 ($P_{f,i}$)	---	---	---
Total auxiliary power from table 2 ($P_{r,i}$)	---	---	---
Net engine power (kW) $P_i = P_{m,i} - P_{f,i} + P_{r,i}$	---	---	4.20

Manufacturer : TAIZHOU NEWLAND MACHINERY CO., LTD.
Engine type designation : BS168F-1

8 Conditions at test

- 8.1. f_a within range 0.93 to 1.07 : Yes/~~No~~
- 8.1.1. If f_a is not within specified range state altitude of test facility and dry atmospheric pressure : ---
- 8.2. Applicable intake air temperature range : 20 to 30/~~0 to -5(snow throwers only)/ -5 to -15(snowmobiles only)/ 20 to 35(NRE greater than 560 kW only)~~

9. Information concerning the conduct of the NRSC test

- 9.1. Cycle (mark cycle used with X) to be stated in Table 4

Table 4 NRSC test cycle

Cycle	C1	C2	D2	E2	E3	F	G1	G2	G3	H
Discrete mode	---	---	---	---	---	---	---	X	---	---
RMC	---	---	---	---	---	---	---	---	---	---

- 9.2. Dynamometer setting (kW) to be stated in Table 5

Table 5 Dynamometer setting

% Load at point or % of rated power (as applicable)	Dynamometer setting (kW) at various engine speeds taking account of net engine power ⁽¹⁾ from Table 3 (complete relevant columns)					
	Idle	63%	80%	91%	Inter-mediate	100%
5%	---	---	---	---	---	---
10%	---	---	---	---	---	0.42
25%	---	---	---	---	---	1.05
50%	---	---	---	---	---	2.10
75%	---	---	---	---	---	3.15
100%	---	---	---	---	---	4.20

(1) The dynamometer setting shall be determined using the procedure set out in point 7.7.1.3 of Annex VI to Delegated Regulation (EU) 2017/654. The auxiliary power in that point shall be determined using the total values set out in Tables 1 and 2 of this Appendix.

9.3. NRSC Emissions results

- 9.3.1. Deterioration Factor (DF) : ~~calculated~~/assigned

- 9.3.2. DF values and the cycle weighted emissions results to be stated in Table 6:
Note: In the event that a discrete mode NRSC is run where the K_{ru} or K_{rd} factors have been established for individual modes then a table showing each mode and the applied K_{ru} or K_{rd} should replace the shown table

Manufacturer : TAIZHOU NEWLAND MACHINERY CO., LTD.
Engine type designation : BS168F-1

Table 6 NRSC cycle DF values and weighted emissions results

DF	CO	HC	NO _x	HC+NO _x	PM	PN
mult/add	1.11	1.03	1.00	--	---	---
Emissions	CO (g/kWh)	HC (g/kWh)	NO _x (g/kWh)	HC+NO _x (g/kWh)	PM (g/kWh)	PN #/kWh
Test result with/without regeneration	396.35	6.25	1.63	7.88	---	---
k_{ru}/k_{rd} mult/add	---	---	---	---	---	---
test result with IRAF	---	---	---	---	---	---
Final test result with DF	439.95	6.44	1.63	8.07	---	---

9.3.3. Cycle weighted CO₂ (g/kWh) : 874.02

9.3.4. Cycle weighted NH₃ (ppm) : ---

9.4. Additional control area test points (if applicable) to be stated in Table 7

Table 7 Additional control area test points

Emissions at test point	Engine Speed	Load (%)	CO (g/kWh)	HC (g/kWh)	NO _x (g/kWh)	HC+NO _x (g/kWh)	PM (g/kWh)	PN n/kWh
Test result 1	---	---	---	---	---	---	---	---
Test result 2	---	---	---	---	---	---	---	---
Test result 3	---	---	---	---	---	---	---	---

9.5. Sampling systems used for the NRSC test

9.5.1. Gaseous emissions : CVS

9.5.2. PM : ---

9.5.2.1 Method : single/multiple filter

9.5.3. Particle number : ---

10. **Information concerning the conduct of the NRTC test (if applicable)**

10.1. Cycle (mark cycle with X) to be stated in Table 8

Table 8 NRTC test cycle

NRTC	---
LSI-NRTC	---

Manufacturer : TAIZHOU NEWLAND MACHINERY CO., LTD.
Engine type designation : BS168F-1

10.2. NRTC emissions results

10.2.1. Deterioration Factor (DF) : ~~calculated~~/fixed

10.2.2. DF values and the emissions results to be stated in Table 9 or in Table 10, as applicable (NRTC or LSI-NRTC):

Table 9 DF values and the emissions results for NRTC

DF mult/add	CO	HC	NO _x	HC+NO _x	PM	PN
	---	---	---	---	---	---
Emissions	CO (g/kWh)	HC (g/kWh)	NO _x (g/kWh)	HC+NO _x (g/kWh)	PM (g/kWh)	PN #/kWh
Cold start	---	---	---	---	---	---
Hot start test result with/without regeneration	---	---	---	---	---	---
Weighted test result	---	---	---	---	---	---
k_{ru}/k_{rd} mult/add	---	---	---	---	---	---
Weighted test result with IRAF	---	---	---	---	---	---
Final test result with DF	---	---	---	---	---	---

10.2.3 Hot cycle CO₂ (g/kWh) : ---

10.2.4 Cycle weighted NH₃ (ppm) : ---

10.2.5 Cycle work for hot start test (kWh) : ---

10.2.6 Cycle CO₂ for hot start test (g) : ---

Table 10 DF values and the emissions results for NRTC-LSI

DF mult/add	CO	HC	NO _x	HC+NO _x	PM	PN
	---	---	---	---	---	---
Emissions	CO (g/kWh)	HC (g/kWh)	NO _x (g/kWh)	HC+NO _x (g/kWh)	PM (g/kWh)	PN #/kWh
Test result with/without regeneration	---	---	---	---	---	---
k_{ru}/k_{rd} mult/add	---	---	---	---	---	---
Test result with IRAF	---	---	---	---	---	---
Final test result with DF	---	---	---	---	---	---

10.3. Cycle CO₂ (g/kWh) : ---

10.4. Cycle NH₃ (ppm) : ---

10.4.1. Cycle work (kWh) : ---

Manufacturer : TAIZHOU NEWLAND MACHINERY CO., LTD.
Engine type designation : BS168F-1

- 10.4.2. Cycle CO₂ (g) : ---
- 10.5. Sampling system used for the NRTC test : ---
- 10.6. Gaseous emissions : ---
- 10.7. PM : ---
- 10.7.1. Method : ~~single/multiple filter~~
- 10.8. Particle number : ---
- 11. **Final emissions results**
- 11.1 Cycle emissions results to be stated in Table 11.

Table 11 Final emissions results

Emissions	CO (g/kWh)	HC (g/kWh)	NO _x (g/kWh)	HC+NO _x (g/kWh)	PM (g/kWh)	PN #/kWh	Test Cycle ⁽¹⁾
NRSC final result with DF ⁽¹⁾	439.95	6.44	1.63	8.07	---	---	G2
NRTC final test result with DF ⁽³⁾	---	---	---	---	---	---	---

11.2 CO₂ result ⁽⁴⁾ (g/kWh) : 874.02

⁽¹⁾ For NRSC note the cycle indicated in point 9.1; for NRTC note cycle indicated in point 10.1.

⁽²⁾ Copy the results from Table 9.3.2.

⁽³⁾ Copy the results from Table 10.2.2 or 10.3.6, as applicable

⁽⁴⁾ For an engine type or engine family that is tested on both the NRTC and NRSC, indicate the hot cycle CO₂ emissions values from the NRTC noted in point 10.3 or the NRTC-LSI noted in point 10.4. For an engine only tested on an NRSC indicate the CO₂ emissions values given in that cycle from point 9.3.3.

Manufacturer : TAIZHOU NEWLAND MACHINERY CO., LTD.
Engine type designation : BS168F-1

- Remark concerning extension : ~~The vehicle type has been tested according to the modification(s) mentioned in appendix 0.~~
~~The new parts meet the requirements of the regulation.~~
An actual practical test of the vehicle was not necessary. The results of the previous test(s) are still valid.
- 11.3 Additional information : The results of the test refer exclusively to the object(s) mentioned under section 2.2 of this report.
- 11.4 Remark : ---
12. **Remarks concerning tested object(s)** : All version of the type as stated in the information document are covered with the tested version(s) and test object(s) respectively.
13. **Appendices**
- Appendix 0 List of modification
Information folder: 2016/1628-BS168F-1-01
14. **Statement of conformity**
- The section 1.9 mentioned information document and the type described in that comply with the requirements mentioned on page 1. The mentioned test results refer to the vehicle(s)/object(s) described under point 2.1 of this report. With regard to the required level of performance to be achieved, the tested samples were representative for the type to be approved (see section 2.5).

Engineering Center Shanghai, August 08, 2018

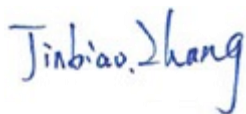

Jinbiao Zhang
Expert Technical Service

Manufacturer : TAIZHOU NEWLAND MACHINERY CO., LTD.
Engine type designation : BS168F-1

List of modifications

Appendix 0

Correction of : ---

Modification of : --The manufacturer is changed to TAIZHOU NEWLAND MACHINERY CO., LTD.
--Make is changed to POWERDYNE, WILKSUSA, GXNEWLAND

Addition of : ---

Deletion of : ---

Contents

Contents		1
	Declaration by manufacturer on compliance with Regulation (EU) 2016/1628	2
Part A	General information	3
Part B	Common design parameters of engine family	4-5
Part C	Essential characteristics of the engine type(s)	6-19
	Photographs of the parent engine	20
	Content of drawings	21-32

Drawing no.	Drawing subject	Page
BS168F-1-01	Position of engine no. and EU approval no.	21
BS168F-1-02	Cylinder	22
BS168F-1-03	Piston	23
BS168F-1-04	Carburettor	24
BS168F-1-05	Catalyst	25
BS168F-1-06	Timing diagram	26
BS168F-1-07	Ignition advance curve	27
BS168F-1-08	Exhaust system	28
BS168F-1-09	Inlet path	29
BS168F-1-10	Engine mapping	30
BS168F-1-11	Device for recycling crankcase gases	31
BS168F-1-12	The structure of engines	32

Declaration by manufacturer on prevention of tampering	33
Statement considering emission durability test and test report	34
Emission durability test report	35-48
Revision(s)	49

Remark: # modification

Declaration by manufacturer on compliance with Regulation (EU) 2016/1628

The undersigned (full name and position): Mr. Yang Guo/Manager

Hereby declares that the following engine type/~~engine family~~ complies in all respects with the requirements of Regulation (EU) 2016/1628 of the European Parliament and of the Council, Commission Delegated Regulation (EU) 2017/654, Commission Delegated Regulation (EU) 2017/655 and Commission Implementing Regulation (EU) 2017/656 and does not use any defeat strategy.

All emission control strategies comply, where applicable, with the requirements for Base Emission Control Strategy (BECS) and Auxiliary Emission Control Strategy (AECS) set-out in section 2 of Annex IV to Delegated Regulation (EU) 2017/654, and have been disclosed in accordance with that Annex and with Annex I to Implementing Regulation (EU) 2017/656.

- 1.1. Make (trade name(s) of manufacturer): POWERDYNE, WILKSUSA, GXNEWLAND
- 1.2. Commercial name(s) (if applicable): Not applicable
- 1.3. Company name and address of manufacturer: TAIZHOU NEWLAND MACHINERY CO., LTD.
NO.1390, West Gongren Road, Jiaojiang, Taizhou City, P.R. China
- 1.4. Name and address of manufacturer's authorized representative (if any): TAGMA D.O.O
SMARSKA CESTA 7C, 6000, KOPER, SLOVENIA
- 1.6. Engine type designation/~~engine family~~ designation/FT: BS168F-1

(Place) (Date) Taizhou August 08, 2018, 2018

Signature (or visual representation of an 'advanced electronic signature' according to Regulation (EU) No 910/2014 of the European Parliament and of the Council (5), including data for verification):



郭杨

Part A

1. GENERAL INFORMATION

1.1.	Make (trade name(s) of manufacturer)	:	POWERDYNE, WILKSUSA, GXNEWLAND	#
1.2.	Commercial name(s) (if applicable)	:	n.a.	
1.3.	Company name and address of manufacturer	:	TAIZHOU NEWLAND MACHINERY CO., LTD. NO.1390, West Gongren Road,Jiaojiang, Taizhou City, P.R. China	# #
1.4.	Name and address of manufacturer's authorised representative (if any)	:	TAGMA D.O.O SMARSKA CESTA 7C, 6000, KOPER, SLOVENIA	
1.5.	Name(s) and address(es) of assembly/ manufacture plant(s)	:	Taizhou Newland Machinery Co., Ltd. NO.1390,West Gongren Road, Jiaojiang,Taizhou City, Zhejiang Province, P.R. China	
1.6.	Engine type designation/ engine family designation /FT	:	BS168F-1	
1.7.	Category and sub-category of the engine type/ engine family	:	NRS-vr-1a	
1.8.	Emissions durability period category	:	Cat 1 (Customer products)	
1.9.	Emissions stage	:	V	
1.10.	In case of NRS <19 kW only, engine family consisting exclusively of engine types for snow throwers	:	No	
1.11.	Reference power is	:	Rated net power	
1.12.	Primary NRSC test cycle	:	G2	
1.12.1.	In case of variable speed IWP category only, Additional propulsion test cycle	:	Not applicable	
1.12.2.	In case of IWP category only, additional auxiliary NRSC test cycle	:	Not applicable	
1.13.	Transient test cycle	:	Not applicable	
1.14.	Restrictions on use (if applicable)	:	n.a.	

Part B

2. COMMON DESIGN PARAMETERS OF ENGINE FAMILY⁽¹⁾

2.1.	Combustion Cycle	:	Four stroke
2.2.	Ignition Type	:	Spark ignition
2.3.	Configuration of the cylinders		
2.3.1.	Position of the cylinders in the block	:	Single
2.3.2.	Bore centre to centre dimension (mm)	:	n.a.
2.4.	Combustion chamber type/design		
2.4.1.	Open chamber/divided chamber/other(specify)	:	n.a.
2.4.2.	Valve and porting configuration	:	Refer to drawing No. BS168F-1-02
2.4.3.	Number of valves per cylinder	:	n.a.
2.5.	Range of individual cylinder displacement (cm ³)	:	196
2.6.	Main Cooling medium	:	Air
2.7.	Method of air aspiration	:	Naturally aspirated
2.8.	Fuel		
2.8.1.	Fuel Type	:	Petrol (E10)
2.8.1.1.	Sub Fuel type (Natural gas/Biomethane only)	:	n.a.
2.8.2.	Fuelling arrangement	:	Liquid-fuel only
2.8.3.	List of additional fuels compatible with use by the engine declared by the manufacturer in accordance with point 1.4. of Annex I to Commission Delegated Regulation 2017/654 on technical and general requirements (provide reference to recognised standard or specification)	:	n.a.
2.8.4.	Lubricant added to fuel	:	No
2.8.4.1.	Specification	:	n.a.
2.8.4.2.	Ratio of fuel to oil	:	n.a.
2.8.5.	Fuel supply type	:	Carburettor
2.9.	Engine management systems	:	Mechanical
2.10.	Miscellaneous devices		
2.10.1.	Exhaust gas recirculation (if yes, complete section 3.10.1. and provide a schematic diagram of the location and order of the devices)	:	No
2.10.2.	Water injection (if yes, complete section 3.10.2.and provide a schematic diagram of the location and order of the devices)	:	No
2.10.3.	Air injection	:	No

- (if yes, complete section 3.10.2.and provide a schematic diagram of the location and order of the devices)
- 2.10.4. H₂ injection : No
(if yes, provide a schematic diagram of the location and order of the devices)
- 2.10.5. Others (specifyandprovide a schematic diagram of the location and order of the devices) : No
- 2.11. Exhaust after-treatment system : Yes
(if yes provide a schematic diagram of the location and order of the devices)
- 2.11.1. Oxidation catalyst : Yes
(if yes, complete section 3.11.2.)
- 2.11.2. DeNO_x system with selective reduction of NO_x (addition of reducing agent) : No
(if yes, complete section 3.11.3.)
- 2.11.3. Other DeNO_x systems : No
(if yes, complete section 3.11.3.)
- 2.11.4. Three-way catalyst combining oxidation and NO_x reduction : No
(if yes, complete section 3.11.3.)
- 2.11.5. Particulate trap with passive regeneration : No
(if yes, complete section 3.11.4.)
- 2.11.6. Particulate trap with active regeneration : No
(if yes, complete section 3.11.4.)
- 2.11.7. Other particulate traps : No
(if yes, complete section 3.11.4.)
- 2.11.8. Other after-treatment devices(specify) : No
(if yes, complete section 3.11.5.)
- 2.11.9. Other devices or features that have a strong influence on emissions (specify) : No

Part C

3. ESSENTIAL CHARACTERISTICS OF THE ENGINE TYPE(S)

Item Number	Item Description	Test	Installation	Homologation	Parent engine/ engine type	Engine types within the engine family (if applicable)
						Type 2
3.1	Engine Identification					
3.1.1.	Engine type designation			X	BS168F-1	
3.1.2.	Engine type designation shown on engine marking: yes/no			X	Yes	
3.1.3.	Location of the statutory marking:			X	Enclosure	
3.1.4.	Method of attachment of the statutory marking:			X	Adhesive label	
3.1.5.	Drawings of the location of the engine identification number (complete example with dimensions):			X	Refer to drawing No. BS168F-1-01	
3.2.	Performance Parameters					
3.2.1.	Declared rated speed (rpm):	X			3600	
3.2.1.1.	Fuel delivery/stroke (mm ³) for diesel engine, fuel flow (g/h) for other engines, at rated net power:			X	1650	
3.2.1.2.	Declared rated net power (kW):	X			4.20	
3.2.2.	Maximum power speed(rpm):			X	3600	
3.2.2.1.	Fuel delivery/stroke (mm ³) for diesel engine, fuel flow (g/h) for other engines, at maximum net power:			X	1650	
3.2.2.2.	Maximum net power (kW):	X		X	4.20	
3.2.3.	Declared maximum torque speed (rpm):	X			3100	
3.2.3.1.	Fuel delivery/stroke (mm ³) for diesel engine, fuel flow (g/h) for other engines, at maximum torque speed:			X	1625	
3.2.3.2.	Declared maximum torque (Nm):	X			11.2	
3.2.4.	Declared 100% test speed:	X			3600	

Item Number	Item Description	Test	Installation	Homologation	Parent engine/ engine type	Engine types within the engine family (if applicable)
						Type 2
3.2.5.	Declared Intermediate test speed:	X			n.a.	
3.2.6.	Idle speed (rpm)	X			1650±200	
3.2.7.	Maximum no load speed (rpm):	X			n.a.	
3.2.8.	Declared minimum torque (Nm)	X			n.a.	
3.3.	Run-in procedure					
3.3.1.	Run in time:	X			3 hour	
3.3.2.	Run-in cycle:	X			G2	
3.4.	Engine test					
3.4.1.	Specific fixture required: Yes/No	X			No	
3.4.1.1.	Engine fixture for test bench and power transmission shaft system to the dyno rotating system description, photograph and/or drawing:	X			n.a.	
3.4.2.	Exhaust mixing chamber permitted by manufacturer: Yes/No	X			No	
3.4.2.1.	exhaust mixing chamber description, photograph and/or drawing:	X			n.a.	
3.4.3.	Manufacturers chosen NRSC: RMC/Discrete mode	X			Discrete mode	
3.4.4.	Additional NRSC: E2/D2/C1	X			n.a.	
3.4.5.	Number of pre-conditioning cycles prior to transient test	X			n.a.	
3.4.6.	Number of pre-conditioning RMC prior to RMC NRSC test	X			n.a.	
3.5.	Lubrication system					
3.5.1.	Lubricant temperature				n.a.	
3.5.1.1.	Minimum (deg. C):	X			70	
3.5.1.2.	Maximum (deg. C):	X			142	
3.6.	Combustion Cylinder					

Item Number	Item Description	Test	Installation	Homologation	Parent engine/ engine type	Engine types within the engine family (if applicable)
						Type 2
3.6.1.	Bore(mm):			X	68	
3.6.2.	Stroke(mm):			X	54	
3.6.3.	Number of cylinders:			X	1	
3.6.4.	Engine displacement (cm ³):			X	196	
3.6.5.	Cylinder displacement as % of parent engine:			X	100	
3.6.6.	Volumetric compression ratio:			X	8.5:1	
3.6.7.	Combustion system description:			X	Spark ignition	
3.6.8.	Drawings of combustion chamber and piston crown:			X	Refer to drawing No. BS168F-1-02 Refer to drawing No. BS168F-1-03	
3.6.9.	Minimum cross sectional area of inlet and outlet ports (mm ²):			X	Inlet: 440.78 Outlet: 428.95	
3.6.10.	Valve timing					
3.6.10.1.	Maximum lift and angles of opening and closing in relation to dead centre or equivalent data:			X	Refer to drawing No. BS168F-1-06	
3.6.10.2.	Reference and/or setting range:			X	TDC	
3.6.10.3.	Variable valve timing system: Yes/No			X	No	
3.6.10.3.1.	Type: continuous/(on/off)			X	n.a.	
3.6.10.3.2.	Cam phase shift angle:			X	n.a.	
3.6.11.	Porting configuration					
3.6.11.1.	Position, size and number:			X	n.a.	
3.7.	Cooling system					
3.7.1.	Liquid cooling					
3.7.1.1.	Nature of liquid:			X	n.a.	
3.7.1.2.	Circulating pumps: Yes/No			X	No	
3.7.1.2.1.	type(s):			X	n.a.	

Item Number	Item Description	Test	Installation	Homologation	Parent engine/ engine type	Engine types within the engine family (if applicable)
						Type 2
3.7.1.2.2.	Drive ratio(s):			X	n.a.	
3.7.1.3.	Minimum coolant temperature at outlet (deg. C):	X			n.a.	
3.7.1.4.	Maximum coolant temperature at outlet (deg. C):	X			n.a.	
3.7.2.	Air cooling					
3.7.2.1.	fan: Yes/No			X	Yes	
3.7.2.1.1.	type(s):			X	168F-1	
3.7.2.1.2.	Drive ratio(s):			X	1	
3.7.2.2.	Maximum temperature at reference point (deg. C):			X	270	
3.7.2.2.1.	Reference point location			X	Spark plug washer	
3.8.	Aspiration					
3.8.1.	Maximum allowable intake depression at 100% engine speed and at 100% load (kPa)	X	X			
3.8.1.1.	With clean air cleaner:	X	X		1.9	
3.8.1.2.	With dirty air cleaner:	X	X		1.9	
3.8.1.3.	Location, of measurement:	X	X		Air inlet nearby	
3.8.2.	Pressure charger(s): Yes/No			X	No	
3.8.2.1.	Type(s):			X	n.a.	
3.8.2.2.	Description and schematic diagram of the system (e.g. maximum charge pressure, waste gate, VGT, Twin turbo, etc.):			X	n.a.	
3.8.3.	Charge air cooler: Yes/No			X	No	
3.8.3.1.	Type: air-air/air-water/other(specify)			X	n.a.	
3.8.3.2.	Maximum charge air cooler outlet temperature at 100% speed and 100% load (deg. C):	X	X		n.a.	

Item Number	Item Description	Test	Installation	Homologation	Parent engine/ engine type	Engine types within the engine family (if applicable)
						Type 2
3.8.3.4.	Maximum allowable pressure drop across charge cooler at 100% engine speed and at 100% load (kPa):	X	X		n.a.	
3.8.4.	Intake throttle valve: Yes/No			X	No	
3.8.5.	Device for recycling crankcase gases: Yes/No			X	Yes	
3.8.5.1.	If yes, description and drawings:			X	Refer to drawing No. BS168F-1-10	
3.8.5.2.	If no, compliance with paragraph 6.10 of Annex VI to Commission Delegated Regulation (EU) 2016/654 on technical and general requirements: Yes/No	X			No	
3.8.6.	Inlet path					
3.8.6.1.	Description of inlet path, (with drawings, photographs and/or part numbers):			X	Refer to drawing No. BS168F-1-09	
3.8.7.	Air filter			X		
3.8.7.1.	Type:			X	168F-1	
3.8.8.	Intake air-silencer					
3.8.1.1.	Type:			X	n.a.	
3.9.	Exhaust system					
3.9.1.	Description of the exhaust system (with drawings, photos and/or part numbers as required):			X	Refer to drawing No. BS168F-1-08	
3.9.2.	Maximum exhaust temperature (deg. C):	X			450	
3.9.3.	Maximum permissible exhaust backpressure at 100% engine speed and at 100% load (kPa):	X	X		5.0	
3.9.3.1.	Location of measurement:	X	X		Exhaust port nearby	
3.9.4.	Exhaust backpressure at loading level specified by manufacturer for variable restriction after-treatment at start of test (kPa):	X			n.a.	
3.9.4.1.	Location and speed/load conditions:	X			n.a.	

Item Number	Item Description	Test	Installation	Homologation	Parent engine/ engine type	Engine types within the engine family (if applicable)
						Type 2
3.9.5.	Exhaust throttle valve: Yes/No			X	No	
3.10.	Miscellaneous devices					
3.10.1.	Exhaust gas recirculation					
3.10.1.1.	Characteristics: cooled/uncooled, high pressure/low pressure/other (specify):				n.a.	
3.10.2.	Water injection					
3.10.2.1.	Operation principle:			X	n.a.	
3.10.3.	H ₂ injection	X			n.a.	
3.11.	Exhaust after-treatment system					
3.11.1.	Location		X			
3.11.1.1.	Place(s) and maximum/minimum distance(s) from engine to first after-treatment device:		X		Minimum distance : 35mm Inside of muffler	
3.11.1.2.	Maximum temperature drop from exhaust or turbine outlet to first after-treatment device (deg. C) if stated:	X	X		n.a.	
3.11.1.2.1.	Test conditions for measurement:	X	X		n.a.	
3.11.1.3.	Minimum temperature at inlet to first after-treatment device at 100% load and speed (deg. C), if stated:	X	X		n.a.	
3.11.2.	Oxidation catalyst					
3.11.2.1.	Number of catalytic converters and elements:			X	1	
3.11.2.2.	Dimensions and volume of the catalytic converter(s):			X	Ø35mm×25mm 21.37 cm ³	
3.11.2.3.	Total charge of precious metals:			X	0.0377±0.005g	
3.11.2.4.	Relative concentration of each compound:			X	Pt :Pd :Rh=1 :1 :0	
3.11.2.5.	Substrate (structure and material):			X	Metallic, Honeycomb, 0Cr21AL6	
3.11.2.6.	Cell density:			X	62±5/ cm ²	

Item Number	Item Description	Test	Installation	Homologation	Parent engine/ engine type	Engine types within the engine family (if applicable)
						Type 2
3.11.2.7.	Type of casing for the catalytic converter(s):			X	DP10424	
3.11.3.	Catalytic exhaust gas after treatment system for NO _x or three way catalyst					
3.11.3.1.	Type:			X	n.a.	
3.11.3.2.	Number of catalytic converters and elements:			X	n.a.	
3.11.3.3.	Type of catalytic action:			X	n.a.	
3.11.3.4.	Dimensions and volume of the catalytic converter(s):			X	n.a.	
3.11.3.5.	Total charge of precious metals:			X	n.a.	
3.11.3.6.	Relative concentration of each compound:			X	n.a.	
3.11.3.7.	Substrate (structure and material):			X	n.a.	
3.11.3.8.	Cell density:			X	n.a.	
3.11.3.9.	Type of casing for the catalytic converter(s):			X	n.a.	
3.11.3.10.	Method of regeneration:	X		X	n.a.	
3.11.3.10.1.	Infrequent regeneration: Yes/No:	X			No	
3.11.3.11.	Normal operating temperature range (deg. C):	X	X		n.a.	
3.11.3.12.	Consumable reagent: Yes/No			X	No	
3.11.3.12.1.	Type and concentration of reagent needed for catalytic action:			X	n.a.	
3.11.3.12.2.	Lowest concentration of the active ingredient present in the reagent that does not activate warning system (CD _{min}) (%vol):			X	n.a.	
3.11.3.12.3.	Normal operational temperature range of reagent:		X		n.a.	
3.11.3.12.4.	International standard:		X	X	n.a.	
3.11.3.13.	NO _x sensor(s): Yes/No			X	No	
3.11.3.13.1.	Type:			X	n.a.	

Item Number	Item Description	Test	Installation	Homologation	Parent engine/ engine type	Engine types within the engine family (if applicable)
						Type 2
3.11.3.13.2.	Location(s)			X	n.a.	
3.11.3.14.	Oxygen sensor(s): Yes/No			X	No	
3.11.3.14.1.	Type:			X	n.a.	
3.11.3.14.2.	Location(s):			X	n.a.	
3.11.4.	Particulate trap					
3.11.4.1.	Type of filtration: through flow/partial flow/wall flow/other (specify)			X	n.a.	
3.11.4.2.	Type:			X	n.a.	
3.11.4.3.	Dimensions and capacity of the particulate trap:			X	n.a.	
3.11.4.4.	Location place(s) and maximum and minimum distance(s) from engine:		X		n.a.	
3.11.4.5.	Method or system of regeneration, description and/or drawing:			X	n.a.	
3.11.4.5.1.	Infrequent regeneration: Yes/No			X	No	
3.11.4.5.2.	Minimum exhaust gas temperature for initiating regeneration procedure (deg. C):			X	n.a.	
3.11.4.6.	Catalytic coating: Yes/No			X	No	
3.11.4.6.1.	Type of catalytic action:			X	n.a.	
3.11.4.7.	Fuel borne catalyst (FBC): Yes/No			X	No	
3.11.4.8.	Normal operating temperature range (deg. C):			X	n.a.	
3.11.4.9.	Normal operating pressure range (kPa)			X	n.a.	
3.11.4.10.	Storage capacity soot/ash [g]:			X	n.a.	
3.11.4.11.	Oxygen sensor(s): Yes/No			X	No	
3.11.4.11.1.	Type:			X	n.a.	
3.11.4.11.2.	Location(s):			X	n.a.	

Item Number	Item Description	Test	Installation	Homologation	Parent engine/ engine type	Engine types within the engine family (if applicable)
						Type 2
3.11.5.	Other systems					
3.11.5.1.	Description and operation:			X	n.a.	
3.11.6.	Infrequent Regeneration					
3.11.6.1.	Number of cycles with regeneration	X			n.a.	
3.11.6.2.	Number of cycles without regeneration	X			n.a.	
3.12.	Fuel feed for diesel or, where applicable, dual fuel engines					
3.12.1.	Feed pump					
3.12.1.1.	Pressure (kPa) or characteristic diagram:			X	n.a.	
3.12.2.	Injection system					
3.12.2.1.	Pump					
3.12.2.1.1.	Type(s):			X	n.a.	
3.12.2.1.2.	Rated pump speed (rpm):			X	n.a.	
3.12.2.1.3.	mm ³ per stroke or cycle at full injection at rated pump speed:			X	n.a.	
3.12.2.1.4.	Torque peak pump speed (rpm):			X	n.a.	
3.12.2.1.5.	mm ³ per stroke or cycle at full injection at torque peak pump speed			X	n.a.	
3.12.2.1.6.	Characteristic diagram:			X	n.a.	
3.12.2.1.7.	Method used: on engine/on pump bench			X	n.a.	
3.12.2.2.	Injection timing					
3.12.2.2.1.	Injection timing curve:			X	n.a.	
3.12.2.2.2.	Static Timing:			X	n.a.	
3.12.2.3.	Injection piping					
3.12.2.3.1.	Length(s) (mm):			X	n.a.	

Item Number	Item Description	Test	Installation	Homologation	Parent engine/ engine type	Engine types within the engine family (if applicable)
						Type 2
3.12.2.3.2.	Internal diameter (mm):			X	n.a.	
3.12.2.4.	Common rail: Yes/No			X	No	
3.12.2.4.1.	Type:			X	n.a.	
3.12.3.	Injector(s)					
3.12.3.1.	Type(s):			X	n.a.	
3.12.3.2.	Opening pressure (kPa):			X	n.a.	
3.12.4.	Electronic control unit (ECU): Yes/No			X	No	
3.12.4.1.	Type(s):			X	n.a.	
3.12.4.2.	Software calibration number(s):			X	n.a.	
3.12.4.3.	Communication standard(s) for access to data stream information:ISO 27145 with ISO 15765-4 (CAN-based)/ISO 27145 with ISO 13400 (TCP/IP-based)/SAE J1939-73	X		X	n.a.	
3.12.5.	Governor					
3.12.5.1.	Type(s):			X	n.a.	
3.12.5.2.	Speed at which cut-off starts under full load:			X	n.a.	
3.12.5.3.	Maximum no-load speed:			X	n.a.	
3.12.5.4.	Idle speed:			X	n.a.	
3.12.6.	Cold-start system: Yes/No			X	No	
3.12.6.1.	Type(s):			X	n.a.	
3.12.6.2.	Description:			X	n.a.	
3.12.7.	Fuel temperature at the inlet to the fuel injection pump					
3.12.7.1.	Minimum (deg. C):	X			n.a.	
3.12.7.2.	Maximum (deg. C):	X			n.a.	
3.13.	Fuel feed for liquid fuel spark ignition engine					

Item Number	Item Description	Test	Installation	Homologation	Parent engine/ engine type	Engine types within the engine family (if applicable)
						Type 2
3.13.1.	Carburettor					
3.13.1.1.	Type(s):			X	1. P19 2. 168F	
3.13.2.	Port fuel injection:				n.a.	
3.13.2.1.	single-point / multi-point			X	n.a.	
3.13.2.2.	Type(s):			X	n.a.	
3.13.3.	Direct injection:				n.a.	
3.13.3.1.	Type(s):			X	n.a.	
3.13.4.	Fuel temperature at location specified by manufacturer					
3.13.4.1.	Location:	X			Fuel tank	
3.13.4.2.	Minimum (deg. C)	X			5	
3.13.4.3.	Maximum (deg. C)	X			30	
3.14.	Fuel feed for gaseous fuel engines or where applicable, dual fuel engines (in the case of systems laid out in a different manner, supply equivalent information)					
3.14.1.	Fuel: LPG /NG-H/NG-L /NG-HL/LNG/Fuel specific LNG	X		X	n.a.	
3.14.2.	Pressure regulator(s) or vaporiser/pressure regulator(s)					
3.14.2.1.	Type(s)			X	n.a.	
3.14.2.2.	Number of pressure reduction stages			X	n.a.	
3.14.2.3.	Pressure in final stage minimum and maximum. (kPa)			X	n.a.	
3.14.2.4.	Number of main adjustment points:			X	n.a.	
3.14.2.5.	Number of idle adjustment points:			X	n.a.	
3.14.3.	Fuelling system: mixing unit/gas injection/liquid injection/direct injection			X	n.a.	

Item Number	Item Description	Test	Installation	Homologation	Parent engine/ engine type	Engine types within the engine family (if applicable)
						Type 2
3.14.3.1.	Mixture strength regulation					
3.14.3.1.1.	System description and/or diagram and drawings:			X	n.a.	
3.14.4.	Mixing unit					
3.14.4.1.	Number:			X	n.a.	
3.14.4.2.	Type(s):			X	n.a.	
3.14.4.3.	Location:			X	n.a.	
3.14.4.4.	Adjustment possibilities:			X	n.a.	
3.14.5.	Inlet manifold injection					
3.14.5.1.	Injection: single-point/multi-point			X	n.a.	
3.14.5.2.	Injection: continuous/simultaneously timed/ sequentially timed			X	n.a.	
3.14.5.3.	Injection equipment					
3.14.5.3.1.	Type(s):			X	n.a.	
3.14.5.3.2.	Adjustment possibilities:			X	n.a.	
3.14.5.4.	Supply pump					
3.14.5.4.1.	Type(s):			X	n.a.	
3.14.5.5.	Injector(s)					
3.14.5.5.1.	Type(s):			X	n.a.	
3.14.6.	Direct injection					
3.14.6.1.	Injection pump/pressure regulator			X	n.a.	
3.14.6.1.1.	Type(s):			X	n.a.	
3.14.6.1.2.	Injection timing (specify):			X	n.a.	
3.14.6.2.	Injector(s)					
3.14.6.2.1.	Type(s):			X	n.a.	
3.14.6.2.2.	Opening pressure or characteristic diagram :			X	n.a.	

Item Number	Item Description	Test	Installation	Homologation	Parent engine/ engine type	Engine types within the engine family (if applicable)
						Type 2
3.14.7.	Electronic Control Unit (ECU)					
3.14.7.1.	Type(s):			X	n.a.	
3.14.7.2.	Adjustment possibilities:			X	n.a.	
3.14.7.3.	Software calibration number(s):			X	n.a.	
3.14.8.	Approvals of engines for several fuel compositions					
3.14.8.1.	Self-adaptive feature: Yes/No	X	X	X	No	
3.14.8.2.	Calibration for a specific gas composition: NG-H/NG-L/NG-HL/ LNG/Fuel specific LNG	X	X	X	n.a.	
3.14.8.3.	Transformation for a specific gas composition: NG-HT/NG-LT/NG-HLT	X	X	X	n.a.	
3.14.9.	Fuel temperature pressure regulator final stage					
3.14.9.1.	Minimum (deg. C):	X			n.a.	
3.14.9.2.	Maximum (deg. C):	X			n.a.	
3.15.	Ignition system					
3.15.1.	Ignition coil(s)					
3.15.1.1.	Type(s):			X	168F-1	
3.15.1.2.	Number:			X	1	
3.15.2.	Spark plug(s)					
3.15.2.1.	Type(s):			X	F6RTC	
3.15.2.2.	Gap setting:			X	0.8-1.0 mm	
3.15.3.	Magneto			X		
3.15.3.1.	Type(s):			X	168F-1	
3.15.4.	Ignition timing control: Yes/No			X	Yes	
3.15.4.1.	Static advance with respect to top dead centre (crank angle degrees):			X	21±1 °	

Item Number	Item Description	Test	Installation	Homologation	Parent engine/ engine type	Engine types within the engine family (if applicable)
						Type 2
3.15.4.2.	Advance curve or map:			X	Refer to drawing No. BS168F-1-07	
3.15.4.3.	Electronic control: Yes/No			X	No	



ENGINE TYPE	BS168F-1
PHOTOGRAPHS OF THE PARENT ENGINE	
PHOTOGRAPH NO.	Photo-01



GXNEW LAND
 EC 163/196/210cc EURO V
 e13*2016/1628*2017/656SRA1/P*0142*01



size:35*20mm
BS168F-1
201808001
 Serial No.: 201808 is year+month

ENGINE TYPE	BS168F-1	
POSITION OF ENGINE NO. AND EU APPROVAL NO.		
DRAWING NO.	BS168F-1-01	#

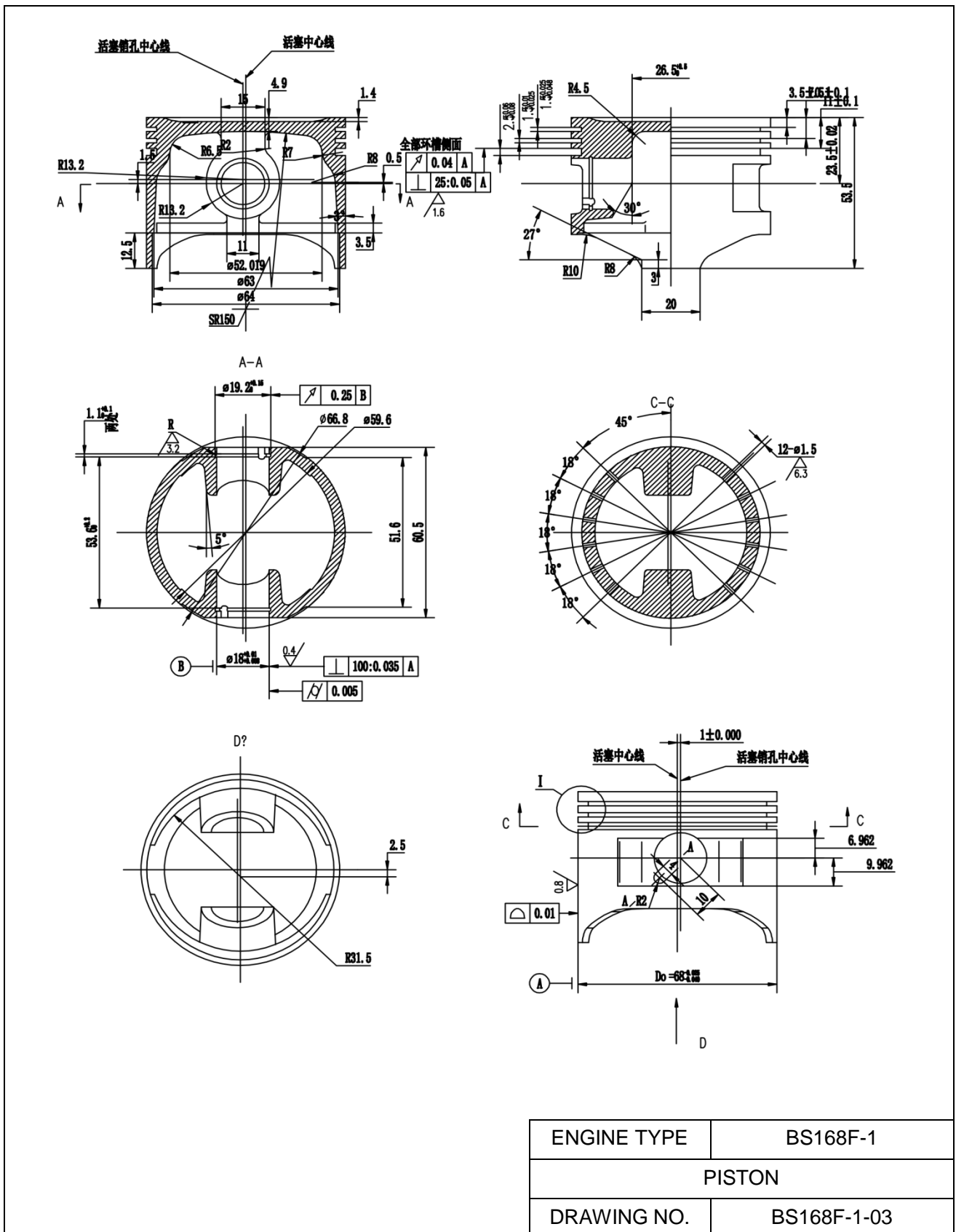

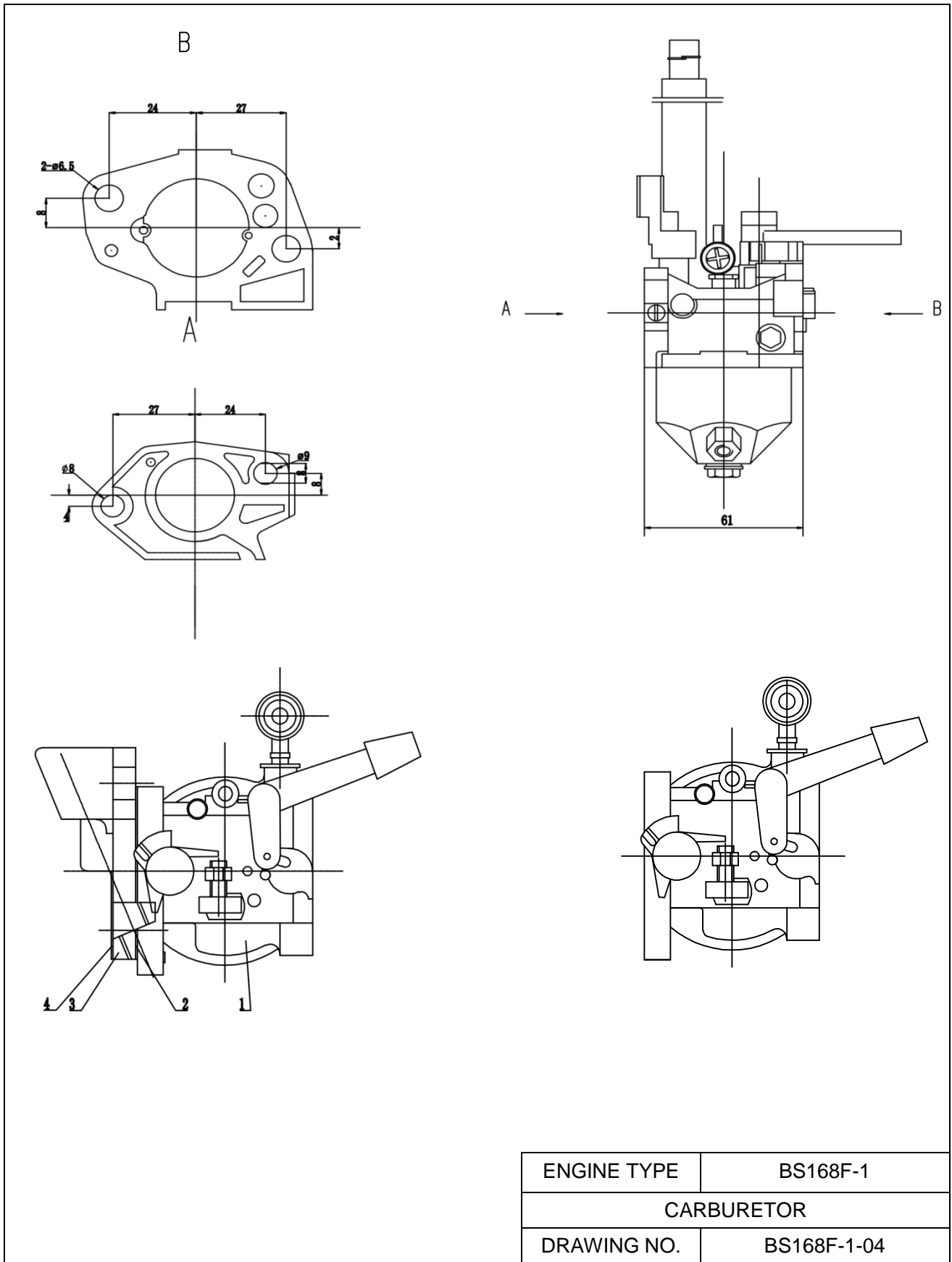

ENGINE TYPE	BS168F-1
CARBURETOR	
DRAWING NO.	BS168F-1-04

技术规格 Technical Specification		
催化剂内芯体积 Catalyst Honeycomb Volume (cm ³)	21.37	
催化剂孔密度 Catalyst Cell Density (cpsi)	400	
贵金属含量 Noble Metals Contents	元素 Element	标称值 Nominal
	Pt (mg)	18.87
	Pd (mg)	18.87
	Rh (mg)	0
贵金属组成 Noble Metals Composition	Pt/Pd/Rh	1:1:0
贵金属总量 Noble Metals Density	标称值 (g/ft ³) Nominal	50
	最小值 (g/ft ³) Minimum	45
载体外壳材料 Shell Material	SUS444	
内芯材料 Honeycomb Material	0Cr21A16	
厂家要求标识 Customer Required Identifier	/	
产品编码 DP Code	DP10424	

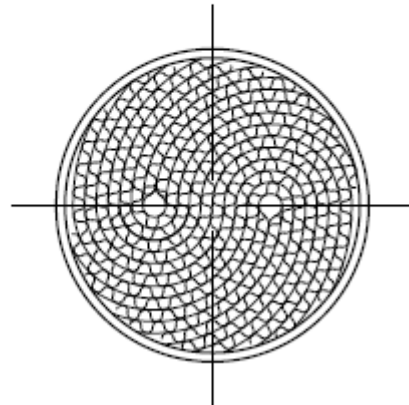
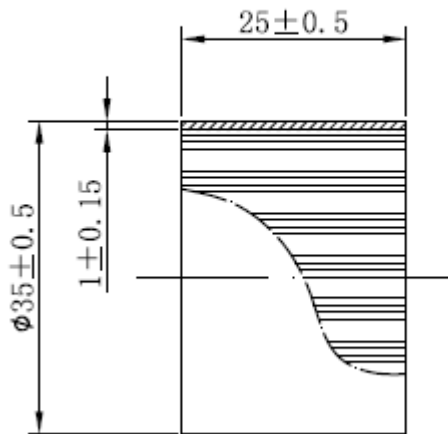

ENGINE TYPE	BS168F-1
CATALYST	
DRAWING NO.	BS168F-1-05

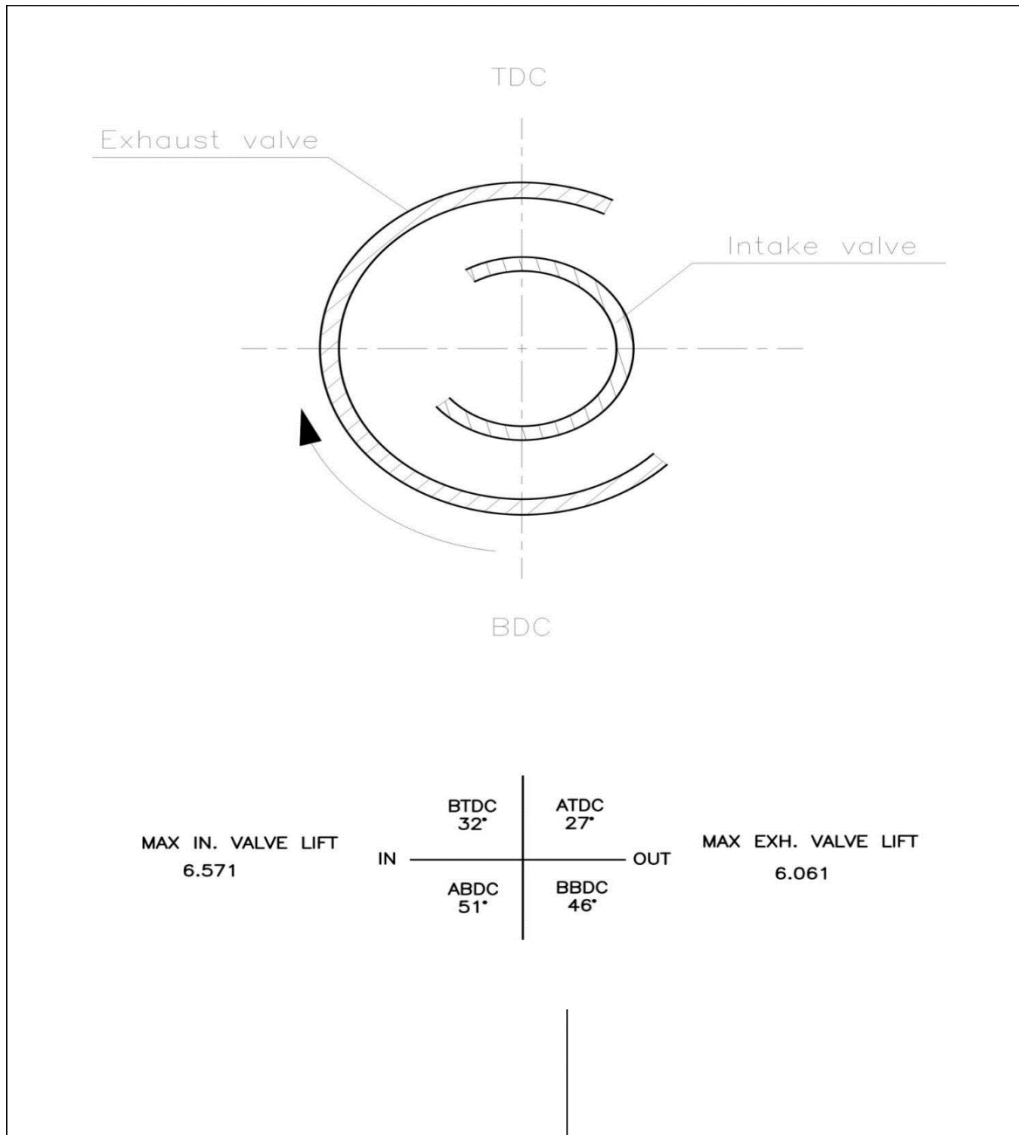

ENGINE TYPE	BS168F-1
TIMING DIAGRAM	
DRAWING NO.	BS168F-1-06

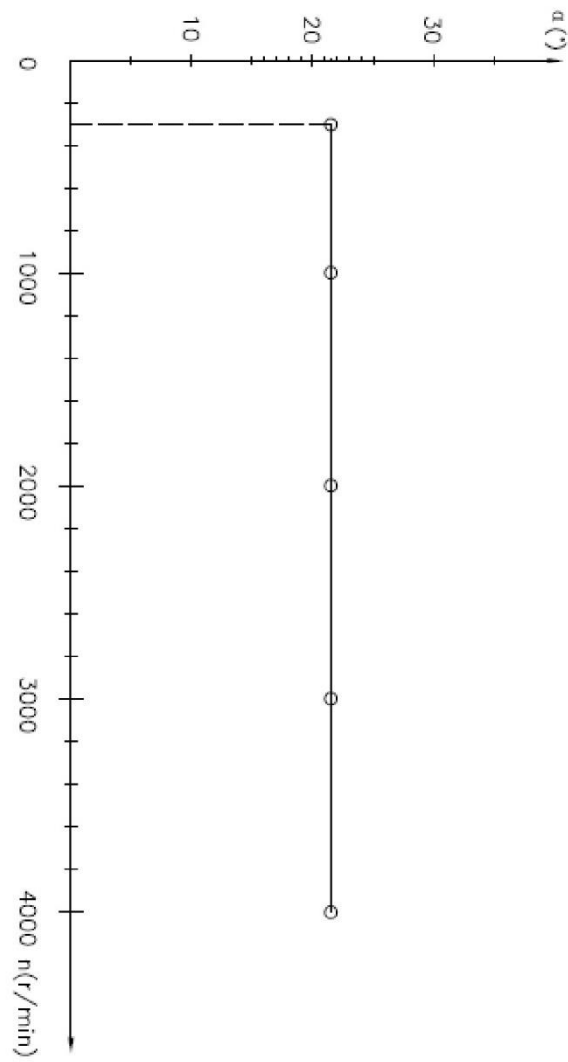

ENGINE TYPE	BS168F-1
IGNITION ADVANCE CURVE	
DRAWING NO.	BS168F-1-07

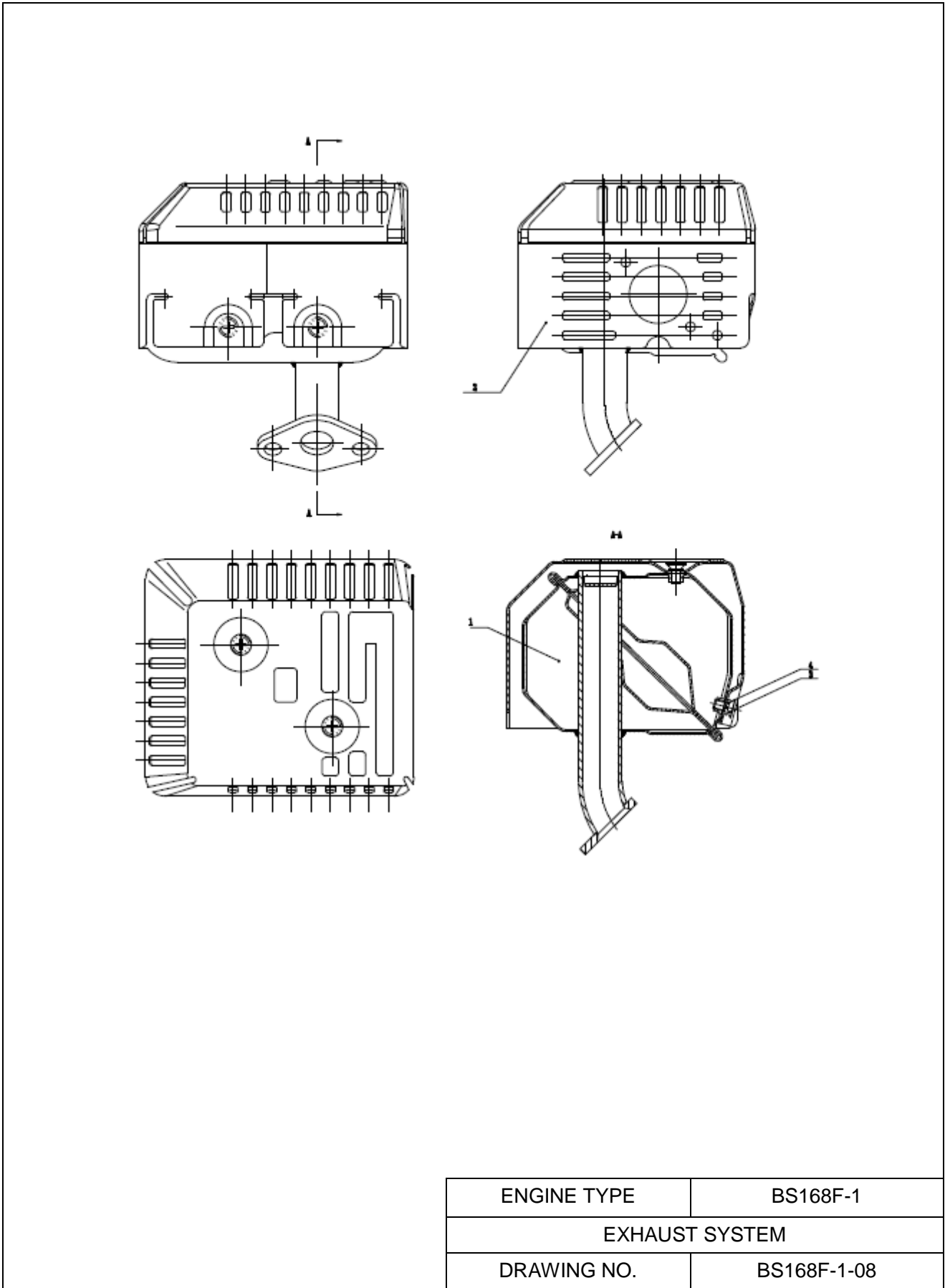

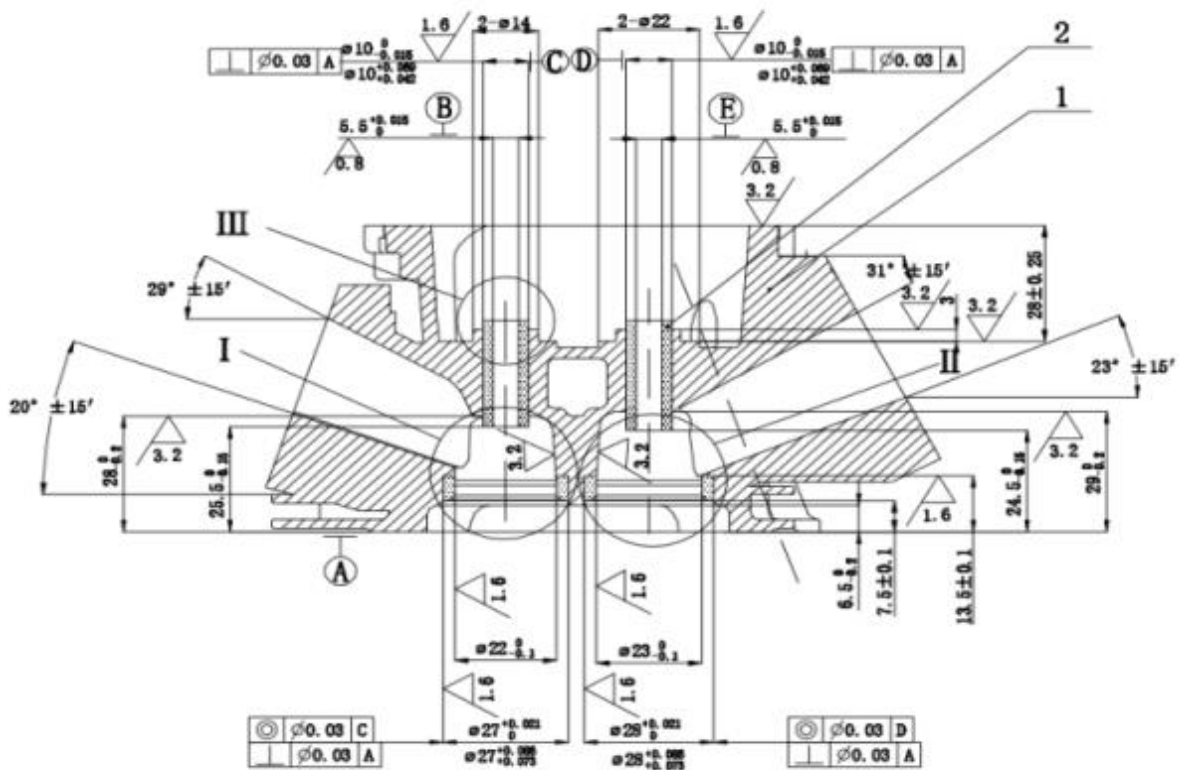

ENGINE TYPE	BS168F-1
INLET PATH	
DRAWING NO.	BS168F-1-09

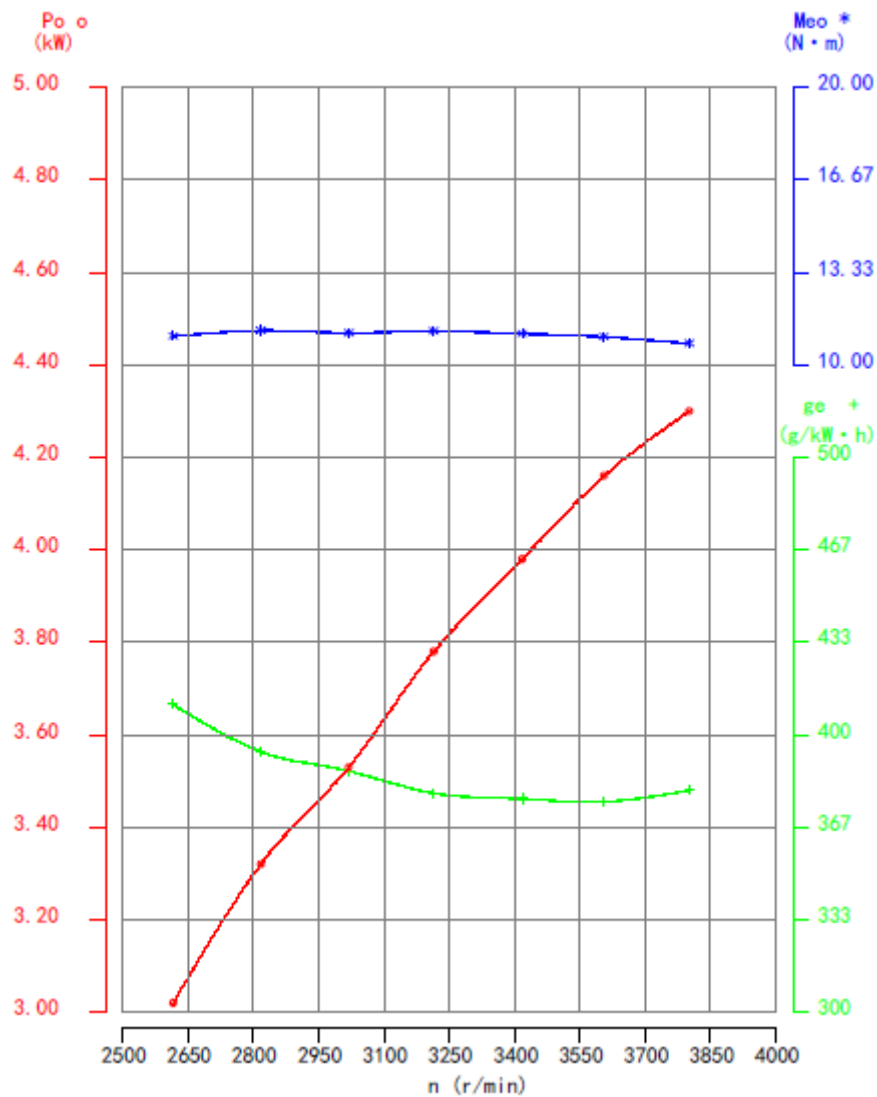

ENGINE TYPE	BS168F-1
ENGINE MAPPING	
DRAWING NO.	BS168F-1-10

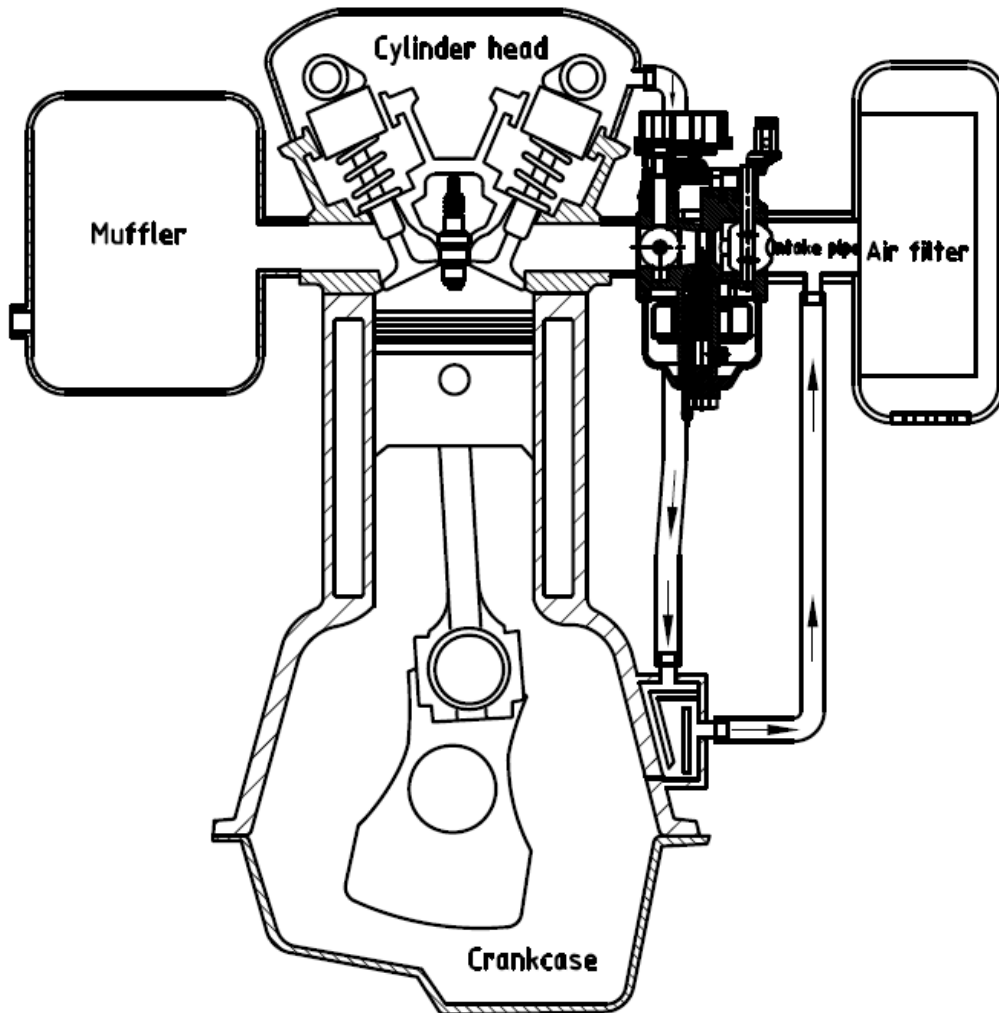

The gases vented from crankcase (cylinder head) during engine running are routed into engine intake system so that it can be combusted in the engine.

ENGINE TYPE	BS168F-1
DEVICE FOR RECYCLING CRANKCASE GASES	
DRAWING NO.	BS168F-1-11

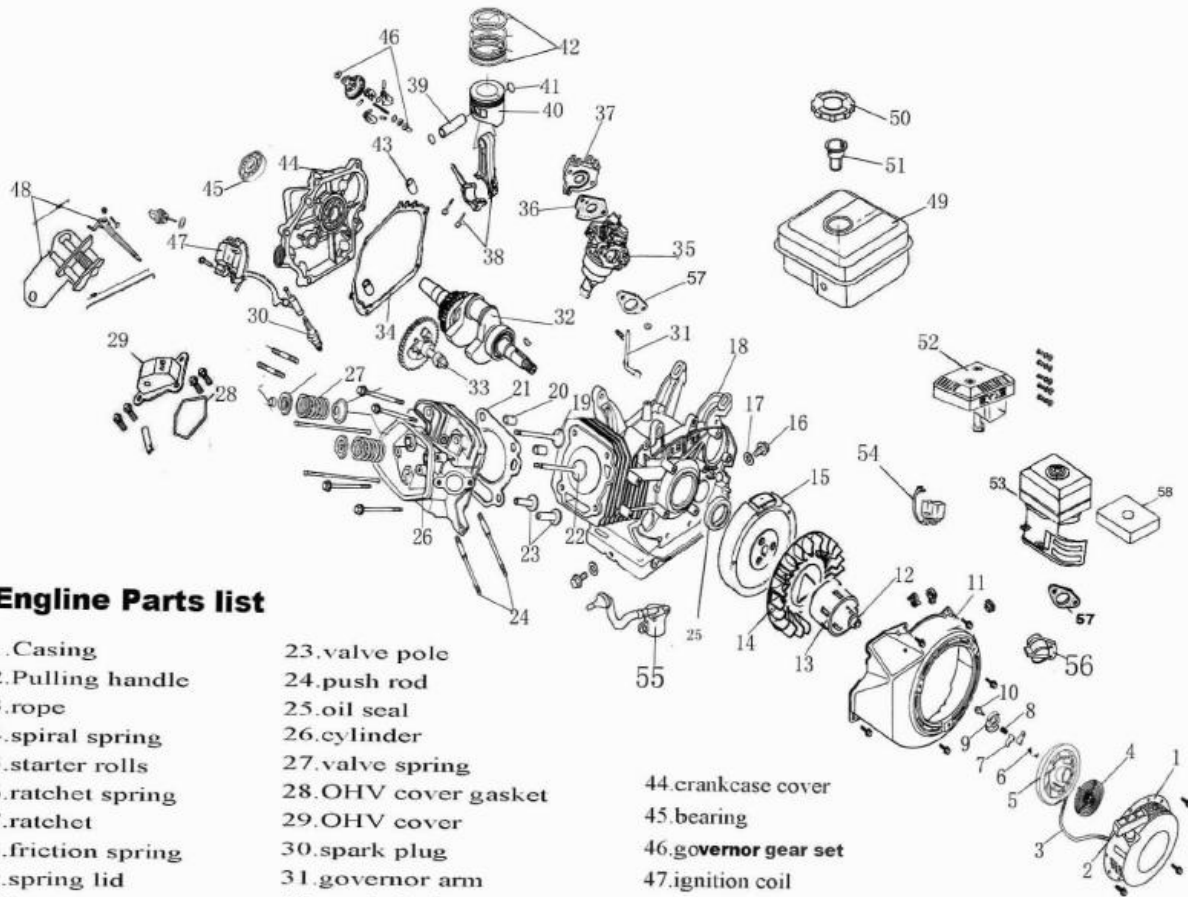

Engine Parts list

- | | | |
|-----------------------|--------------------------|------------------------|
| 1. Casing | 23. valve pole | 44. crankcase cover |
| 2. Pulling handle | 24. push rod | 45. bearing |
| 3. rope | 25. oil seal | 46. governor gear set |
| 4. spiral spring | 26. cylinder | 47. ignition coil |
| 5. starter rolls | 27. valve spring | 48. speed control assy |
| 6. ratchet spring | 28. OHV cover gasket | 49. fuel tank |
| 7. ratchet | 29. OHV cover | 50. tank cap |
| 8. friction spring | 30. spark plug | 51. filter cup |
| 9. spring lid | 31. governor arm | 52. muffler |
| 10. set screw | 32. crankshaft | 53. air cleaner |
| 11. fan hood | 33. camshaft | 54. single sensor |
| 12. flywheel nut | 34. crankcase gasket | 55. oil level switch |
| 13. starter pulley | 35. carburetor | 56. engine switch |
| 14. cooling fan | 36. carburetor gasket | 57. air cleaner gasket |
| 15. flywheel | 37. connecting block | 58. air filter |
| 16. drain plug | 38. connecting rod | |
| 17. drain plug gasket | 39. piston pin | |
| 18. crankcase | 40. piston | |
| 19. intake valve | 41. pin clip | |
| 20. gasket pin | 42. piston ring set | |
| 21. cylinder gasket | 43. crankcase gasket pin | |
| 22. exhaust valve | | |

ENGINE TYPE	BS168F-1
THE STRUCTURE OF ENGINES	
DRAWING NO.	BS168F-1-12

Declaration by manufacturer on prevention of tampering

The undersigned (full name and position): Du Jinzhong /Manager

Hereby declares that the emission control strategies of the following engine type/~~engine family~~ fitted are designed in such a way as to prevent tampering to the extent possible, as referred to in Article 18(4) of Regulation (EU) 2016/1628 of the European Parliament and of the Council and Annex X of Commission Implementing Regulation (EU) 2017/656.

- 1.1. Maker (trade name(s) of manufacturer): POWERDYNE, WILKSUSA, GXNEWLAND
- 1.2. Commercial name(s) (if applicable): Not applicable
- 1.3. Company name and address of manufacturer: TAIZHOU NEWLAND MACHINERY CO., LTD.
NO.1390, West Gongren Road, Jiaojiang, Taizhou City, P.R. China
- 1.4. Name and address of manufacturer's authorized representative (if any): TAGMA D.O.O
SMARSKA CESTA 7C, 6000, KOPER, SLOVENIA
- 1.6. Engine type designation/~~engine family~~ designation/ FT: BS168F-1

Technical details:

The mixing ratio adjusting screw is broken and it is stuck by glue. The glue has very good fixed performance and it can't be destroyed by water and oil. The photo is as follow:



Rich/lean
screw

(Place) (Date) Taizhou/ August 08, 2018

Signature:



郭杨

Statement considering emission durability test

To whom it may concern,

We, Taizhou Newland Machinery Co., Ltd., hereby declare that the emission durability parameters are as below for the small gasoline engine type designation BS168F-1.

Engine type designation	BS168F-1	
Specification of machinery to be propelled by the engine	Generator	
EDP category (hours)	Category 1, 125 hours	
DF (deterioration factor)	CO	1.11
	HC	1.03
	No _x	1.00

This statement refers exclusively to the emission durability report.

Sincerely yours



郭杨

Date: August 08, 2018

Make : **POWERDYNE, WILKSUSA, GXNEWLAND** #
Name and address of the manufacturer : **TAIZHOU NEWLAND MACHINERY CO., LTD.**
NO.1390, West Gongren Road, Jiaojiang, Taizhou City,
P.R. China #

EMISSION DURABILITY TEST REPORT

according to Regulation of the European Parliament and of the Council

**on requirements relating to gaseous and particulate pollutant emission limits and type-approval
for internal combustion engines for non-road mobile machinery**

2016/1628/EU

including all amendments until

2017/656/EU

0. General information

- 0.1 Make (trade name of the manufacturer) : POWERDYNE, WILKSUSA,
GXNEWLAND #
- 0.2 Engine type designation : BS168F-1
- 0.3 Category and sub-category of engine : NRS-vr-1a
- 0.4 Name and address of the manufacturer : TAIZHOU NEWLAND MACHINERY
CO., LTD. #
NO.1390, West Gongren Road, Jiaojiang,
Taizhou City, P.R. China #
- 0.5 Specification of machinery to be propelled : Generator
by the engine

1. Test information

- 1.1 Test object(s)
- identification number : 17A150002
 version : --
- 1.2 Test date : November 11, 2017 –February 08, 2018
- 1.3 Test site : Nanjing Depurate Catalyst Co., Ltd.
No.18 Youshan Road , Gaochun Economic
Develop Zone , Nanjing 211300 , China
- 1.4 Test facilities : The test equipment used was in
compliance with the requirements of the
regulation.

- 1.5 Information concerning the conduct of the test(s)
 - 1.5.1 Reference fuel used for test : E10
 - 1.5.1.1 Octane number
 - Ron : 96.1
 - Mon : 85.9
 - 1.5.1.2 State percentage of oil in mixture when lubricant and petrol are mixed as in the case of two stroke engines : n.a.
 - 1.5.1.3 Density of petrol for four-stroke engines and petrol/oil mixture for two stroke engines : 0.753g/cm³
 - 1.5.2 Lubricant
 - 1.5.2.1 Make(s) : Mobil
 - 1.5.2.2 Type(s) : 4T SF, SAE 20W-40
 - 1.5.3 Emission durability test cycle : Rated Speed
- 1.6 Engine performance
 - 1.6.1 Engine speeds
 - Idle [min⁻¹] : 1650±200
 - Intermediate [min⁻¹] : n.a.
 - Rated [min⁻¹] : 3600
 - 1.6.2 Rated power [kW] : 4.20
- 1.7 Emission durability test
 - 1.7.1 Emission durability period [h] : 125
 - 1.7.2 Engine's maintenance rules during the emission durability test : Refer to appendix 1
 - 1.7.3 The rule of emission durability test : Refer to appendix 2

1.7.4 Emission durability test record : Refer to appendix 3

2 Test result

Item	HC (g/kWh)	CO (g/kWh)	NOx (g/kWh)	HC+NOx (g/kWh)	CO ₂ (g/kWh)
Emission test result (0 hour)	6.25	396.35	1.63	7.88	874.02
Emission test result (125 hours)	6.44	439.95	1.63	8.07	--
DF value	1.03	1.11	1.00	--	--

3 Appendixes

1 Engine's maintenance rules during the emission durability test

2 The rule of emission durability test

3 Emission durability test record

Engine's maintenance rules during the emission durability test

Appendix 1

Item	Time	Remark
Air cleaner	Checked every 25h Changed if necessary	Dried after cleaning
Spark plug(s)	Checked every 25h Cleaned every 25h	Changed if necessary
Normal inspection	Any time	At least 1 time every 24h

The rule of emission durability test

Appendix 2

Mode	Load (%)	Engine speed (min^{-1})	Torque (N.m)	Time ratio (%)	Time (min)
1	100	3600	--	100	60
Each emission durability cycle is 1 hour					

Emission durability test record

Appendix 3

Date	Time (h)	Required time	Engine speed (min ⁻¹)	Actual engine power (KW)	Actual torque (N.M)	Fuel flow rate (kg/h)	Temperature of spark plug washer (°C)	Air pressure (kPa)	Ambient temperature (°C)	Relative humidity (%)
3.22	1	7:00-8:00	3605	4.16	11.02	1.63	230	102.4	21	27
	2	8:00-9:00	3622	4.20	10.98	1.61	230	102.4	21	27
	3	9:00-10:00	3590	4.10	11.12	1.58	230	102.4	21	27
	4	10:00-11:00	3610	4.12	11.02	1.63	230	102.4	21	27
	5	11:00-12:00	3605	4.16	11.02	1.63	230	102.4	21	27
	6	12:00-13:00	3622	4.21	10.98	1.61	230	102.4	21	27
	7	13:00-14:00	3602	4.16	11.00	1.62	230	102.4	21	27
	8	14:00-15:00	3590	4.10	11.12	1.58	230	102.4	21	27
	9	15:00-16:00	3611	4.12	11.02	1.63	230	102.4	21	27
	10	16:00-17:00	3595	4.08	11.10	1.58	230	102.4	21	27
	11	17:00-18:00	3601	4.16	11.02	1.63	230	102.4	21	27
	12	18:00-19:00	3605	4.16	11.02	1.63	230	102.4	21	27
	13	19:00-20:00	3605	4.16	11.02	1.63	230	102.4	21	27
	14	20:00-21:00	3622	4.21	10.98	1.61	230	102.4	21	27
	15	21:00-22:00	3602	4.16	11.00	1.62	230	102.4	21	27

	16	22:00-23:00	3590	4.10	11.12	1.58	230	102.4	21	27
	17	23:00-24:00	3611	4.12	11.02	1.63	230	102.4	21	27
	18	24:00-1:00	3595	4.08	11.10	1.58	230	102.4	21	27
	19	1:00-2:00	3601	4.16	11.02	1.63	230	102.4	21	27
	20	2:00-3:00	3605	4.16	11.02	1.63	230	102.4	21	27
	21	3:00-4:00	3610	4.12	11.02	1.63	230	102.4	21	27
	22	4:00-5:00	3605	4.16	11.02	1.63	230	102.4	21	27
	23	5:00-6:00	3622	4.21	10.98	1.61	230	102.4	21	27
	24	6:00-7:00	3602	4.16	11.00	1.62	230	102.4	21	27
	25	7:00-8:00	3605	4.16	11.02	1.63	230	102.4	21	27
	26	8:00-9:00	3622	4.20	10.98	1.61	230	102.4	21	27
	27	9:00-10:00	3590	4.10	11.12	1.58	230	102.4	21	27
	28	10:00-11:00	3610	4.12	11.02	1.63	230	102.4	21	27
	29	11:00-12:00	3605	4.16	11.02	1.63	230	102.4	21	27
	30	12:00-13:00	3622	4.21	10.98	1.61	230	102.4	21	27
	31	13:00-14:00	3602	4.16	11.00	1.62	230	102.4	21	27
	32	14:00-15:00	3590	4.10	11.12	1.58	230	102.4	21	27
	33	15:00-16:00	3611	4.12	11.02	1.63	230	102.4	21	27

	34	16:00-17:00	3595	4.08	11.10	1.58	230	102.4	21	27
	35	17:00-18:00	3601	4.16	11.02	1.63	230	102.4	21	27
	36	18:00-19:00	3605	4.16	11.02	1.63	230	102.4	21	27
	37	19:00-20:00	3605	4.16	11.02	1.63	230	102.4	21	27
	38	20:00-21:00	3622	4.21	10.98	1.61	230	102.4	21	27
	39	21:00-22:00	3602	4.16	11.00	1.62	230	102.4	21	27
	40	22:00-23:00	3590	4.10	11.12	1.58	230	102.4	21	27
	41	23:00-24:00	3611	4.12	11.02	1.63	230	102.4	21	27
	42	24:00-1:00	3595	4.08	11.10	1.58	230	102.4	21	27
	43	1:00-2:00	3601	4.16	11.02	1.63	230	102.4	21	27
	44	2:00-3:00	3605	4.16	11.02	1.63	230	102.4	21	27
	45	3:00-4:00	3610	4.12	11.02	1.63	230	102.4	21	27
	46	4:00-5:00	3605	4.16	11.02	1.63	230	102.4	21	27
	47	5:00-6:00	3622	4.21	10.98	1.61	230	102.4	21	27
	48	6:00-7:00	3602	4.16	11.00	1.62	230	102.4	21	27
	49	7:00-8:00	3605	4.16	11.02	1.63	230	102.4	21	27
	50	8:00-9:00	3622	4.20	10.98	1.61	230	102.4	21	27
	51	9:00-10:00	3590	4.10	11.12	1.58	230	102.4	21	27

	52	10:00-11:00	3610	4.12	11.02	1.63	230	102.4	21	27
	53	11:00-12:00	3605	4.16	11.02	1.63	230	102.4	21	27
	54	12:00-13:00	3622	4.21	10.98	1.61	230	102.4	21	27
	55	13:00-14:00	3602	4.16	11.00	1.62	230	102.4	21	27
	56	14:00-15:00	3590	4.10	11.12	1.58	230	102.4	21	27
	57	15:00-16:00	3611	4.12	11.02	1.63	230	102.4	21	27
	58	16:00-17:00	3595	4.08	11.10	1.58	230	102.4	21	27
	59	17:00-18:00	3601	4.16	11.02	1.63	230	102.4	21	27
	60	18:00-19:00	3605	4.16	11.02	1.63	230	102.4	21	27
	61	19:00-20:00	3605	4.16	11.02	1.63	230	102.4	21	27
	62	20:00-21:00	3622	4.21	10.98	1.61	230	102.4	21	27
	63	21:00-22:00	3602	4.16	11.00	1.62	230	102.4	21	27
	64	22:00-23:00	3590	4.10	11.12	1.58	230	102.4	21	27
	65	23:00-24:00	3611	4.12	11.02	1.63	230	102.4	21	27
	66	24:00-1:00	3595	4.08	11.10	1.58	230	102.4	21	27
	67	1:00-2:00	3601	4.16	11.02	1.63	230	102.4	21	27
	68	2:00-3:00	3605	4.16	11.02	1.63	230	102.4	21	27
	69	3:00-4:00	3610	4.12	11.02	1.63	230	102.4	21	27

	70	4:00-5:00	3605	4.16	11.02	1.63	230	102.4	21	27
	71	5:00-6:00	3622	4.21	10.98	1.61	230	102.4	21	27
	72	6:00-7:00	3602	4.16	11.00	1.62	230	102.4	21	27
	73	7:00-8:00	3605	4.16	11.02	1.63	230	102.4	21	27
	74	8:00-9:00	3622	4.20	10.98	1.61	230	102.4	21	27
	75	9:00-10:00	3590	4.10	11.12	1.58	230	102.4	21	27
	76	10:00-11:00	3610	4.12	11.02	1.63	230	102.4	21	27
	77	11:00-12:00	3605	4.16	11.02	1.63	230	102.4	21	27
	78	12:00-13:00	3622	4.21	10.98	1.61	230	102.4	21	27
	79	13:00-14:00	3602	4.16	11.00	1.62	230	102.4	21	27
	80	14:00-15:00	3590	4.10	11.12	1.58	230	102.4	21	27
	81	15:00-16:00	3611	4.12	11.02	1.63	230	102.4	21	27
	82	16:00-17:00	3595	4.08	11.10	1.58	230	102.4	21	27
	83	17:00-18:00	3601	4.16	11.02	1.63	230	102.4	21	27
	84	18:00-19:00	3605	4.16	11.02	1.63	230	102.4	21	27
	85	19:00-20:00	3605	4.16	11.02	1.63	230	102.4	21	27
	86	20:00-21:00	3622	4.21	10.98	1.61	230	102.4	21	27
	87	21:00-22:00	3602	4.16	11.00	1.62	230	102.4	21	27

	88	22:00-23:00	3590	4.10	11.12	1.58	230	102.4	21	27
	89	23:00-24:00	3611	4.12	11.02	1.63	230	102.4	21	27
	90	24:00-1:00	3595	4.08	11.10	1.58	230	102.4	21	27
	91	1:00-2:00	3601	4.16	11.02	1.63	230	102.4	21	27
	92	2:00-3:00	3605	4.16	11.02	1.63	230	102.4	21	27
	93	3:00-4:00	3610	4.12	11.02	1.63	230	102.4	21	27
	94	4:00-5:00	3605	4.16	11.02	1.63	230	102.4	21	27
	95	5:00-6:00	3622	4.21	10.98	1.61	230	102.4	21	27
	96	6:00-7:00	3602	4.16	11.00	1.62	230	102.4	21	27
	97	7:00-8:00	3605	4.16	11.02	1.63	230	102.4	21	27
	98	8:00-9:00	3622	4.20	10.98	1.61	230	102.4	21	27
	99	9:00-10:00	3590	4.10	11.12	1.58	230	102.4	21	27
	100	10:00-11:00	3610	4.12	11.02	1.63	230	102.4	21	27
	101	11:00-12:00	3605	4.16	11.02	1.63	230	102.4	21	27
	102	12:00-13:00	3622	4.21	10.98	1.61	230	102.4	21	27
	103	13:00-14:00	3602	4.16	11.00	1.62	230	102.4	21	27
	104	14:00-15:00	3590	4.10	11.12	1.58	230	102.4	21	27
	105	15:00-16:00	3611	4.12	11.02	1.63	230	102.4	21	27

	106	16:00-17:00	3595	4.08	11.10	1.58	230	102.4	21	27
	107	17:00-18:00	3601	4.16	11.02	1.63	230	102.4	21	27
	108	18:00-19:00	3605	4.16	11.02	1.63	230	102.4	21	27
	109	19:00-20:00	3605	4.16	11.02	1.63	230	102.4	21	27
	110	20:00-21:00	3622	4.21	10.98	1.61	230	102.4	21	27
	111	21:00-22:00	3602	4.16	11.00	1.62	230	102.4	21	27
	112	22:00-23:00	3590	4.10	11.12	1.58	230	102.4	21	27
	113	23:00-24:00	3611	4.12	11.02	1.63	230	102.4	21	27
	114	24:00-1:00	3595	4.08	11.10	1.58	230	102.4	21	27
	115	1:00-2:00	3601	4.16	11.02	1.63	230	102.4	21	27
	116	2:00-3:00	3605	4.16	11.02	1.63	230	102.4	21	27
	117	3:00-4:00	3610	4.12	11.02	1.63	230	102.4	21	27
	118	4:00-5:00	3605	4.16	11.02	1.63	230	102.4	21	27
	119	5:00-6:00	3622	4.21	10.98	1.61	230	102.4	21	27
	120	6:00-7:00	3602	4.16	11.00	1.62	230	102.4	21	27
	121	7:00-8:00	3605	4.16	11.02	1.63	230	102.4	21	27
	122	8:00-9:00	3622	4.20	10.98	1.61	230	102.4	21	27
	123	9:00-10:00	3590	4.10	11.12	1.58	230	102.4	21	27

	124	10:00-11:00	3610	4.12	11.02	1.63	230	102.4	21	27
	125	11:00-12:00	3605	4.16	11.02	1.63	230	102.4	21	27
	126	12:00-13:00	3622	4.21	10.98	1.61	230	102.4	21	27
	127	13:00-14:00	3602	4.16	11.00	1.62	230	102.4	21	27
	128	14:00-15:00	3590	4.10	11.12	1.58	230	102.4	21	27
	129	15:00-16:00	3611	4.12	11.02	1.63	230	102.4	21	27
	130	16:00-17:00	3595	4.08	11.10	1.58	230	102.4	21	27
	131	17:00-18:00	3601	4.16	11.02	1.63	230	102.4	21	27
	132	18:00-19:00	3605	4.16	11.02	1.63	230	102.4	21	27
	133	19:00-20:00	3605	4.16	11.02	1.63	230	102.4	21	27
	134	20:00-21:00	3622	4.21	10.98	1.61	230	102.4	21	27
	135	21:00-22:00	3602	4.16	11.00	1.62	230	102.4	21	27
	136	22:00-23:00	3590	4.10	11.12	1.58	230	102.4	21	27
	137	23:00-24:00	3611	4.12	11.02	1.63	230	102.4	21	27
	138	24:00-1:00	3595	4.08	11.10	1.58	230	102.4	21	27
	139	1:00-2:00	3601	4.16	11.02	1.63	230	102.4	21	27
	140	2:00-3:00	3605	4.16	11.02	1.63	230	102.4	21	27
	141	3:00-4:00	3610	4.12	11.02	1.63	230	102.4	21	27

	142	4:00-5:00	3605	4.16	11.02	1.63	230	102.4	21	27
	143	5:00-6:00	3622	4.21	10.98	1.61	230	102.4	21	27
	144	6:00-7:00	3602	4.16	11.00	1.62	230	102.4	21	27
	145	8:00-9:00	3622	4.20	10.98	1.61	230	102.4	21	27
	146	9:00-10:00	3590	4.10	11.12	1.58	230	102.4	21	27
	147	10:00-11:00	3610	4.12	11.02	1.63	230	102.4	21	27
	148	11:00-12:00	3605	4.16	11.02	1.63	230	102.4	21	27
	149	12:00-13:00	3622	4.21	10.98	1.61	230	102.4	21	27
	150	13:00-14:00	3602	4.16	11.00	1.62	230	102.4	21	27



郭杨

Date: February 08, 2018
Du Jinzhong /Manager

REVISION(S)

HISTORY

Rev. Date	Rev. No.	Description	Page No.
August 08, 2018	01	The manufacturer is changed to TAIZHOU NEWLAND MACHINERY CO., LTD.	3, 21, 35, 36
		Make is changed to POWERDYNE, WILKSUSA, GXNEWLAND	3, 35, 36